



Single Port and Multiport Decimator D4 User's Manual





Proprietary Notice

The information contained herein is proprietary to Calian, and may not be used, reproduced, or disclosed to others except as specifically permitted in writing by Calian. The recipient of this information, by its retention and use, agrees to protect the same and the information contained herein from loss, theft, and compromise.



Note:

This equipment has been tested and found to comply with the limits for a Class A digital device, pursuant to Part 15 of the FCC Rules. These limits are designed to provide reasonable protection against harmful interference when the equipment is operated in a commercial environment. This equipment generates, uses, and can radiate radio frequency energy and, if not installed and used in accordance with the instruction manual, may cause harmful interference to radio communications. Operation of this equipment in a residential area is likely to cause harmful interference in which case the user will be required to correct the interference at his own expense.

Contents

	Page
1. Operations Guide	1
1.1 <i>Single Port Decimator.....</i>	<i>1</i>
1.1.1 <i>Connecting the D4 Card to an ATX Power Supply</i>	<i>3</i>
1.2 <i>Multiport Decimator.....</i>	<i>4</i>
1.3 <i>Client Computer</i>	<i>4</i>
2. Reference Manual.....	5
2.1 <i>Decimator Installation</i>	<i>5</i>
2.1.1 <i>Decimator Setup</i>	<i>5</i>
2.1.2 <i>GUI Connections</i>	<i>6</i>
2.1.3 <i>Self-Signed Certificate Warning.....</i>	<i>6</i>
2.1.4 <i>Input Signal Considerations</i>	<i>8</i>
2.1.5 <i>10 MHz Reference Considerations</i>	<i>8</i>
2.1.6 <i>Safety Considerations.....</i>	<i>9</i>
2.2 <i>Web GUI</i>	<i>10</i>
2.2.1 <i>Launch.....</i>	<i>11</i>
2.2.2 <i>Apps</i>	<i>12</i>
2.2.3 <i>Configuration.....</i>	<i>16</i>
2.2.3.1 <i>Network.....</i>	<i>18</i>
2.2.3.2 <i>User Accounts</i>	<i>23</i>
2.2.3.3 <i>Calibration</i>	<i>27</i>
2.2.3.4 <i>Port Names.....</i>	<i>31</i>
2.2.3.5 <i>Certificates</i>	<i>32</i>

Contents (cont'd)

		Page
	2.2.3.6 License.....	34
	2.2.3.7 Remote Access	35
	2.2.3.8 Firmware.....	40
	2.2.3.9 Reset.....	41
	2.2.3.10 Recent Connections.....	42
	2.2.3.11 Open Source Notices	43
	2.2.3.12 Contact Us	44
	2.2.3.13 Help.....	44
2.2.4	Spectrum	45
	2.2.4.1 Main Screen	45
	2.2.4.2 Spectrum Menu	47
	2.2.4.3 Overview Bar	68
	2.2.4.4 Cross-Polarity Mode.....	70
	2.2.4.5 Masks.....	71
	2.2.4.6 Carrier Monitor.....	72
2.2.5	Spectator/Detector.....	80
	2.2.5.1 Database Installation	80
	2.2.5.2 Spectator/Detector Dashboard	80
	2.2.5.3 Spectator/Detector Historic View	85
2.2.6	Waterfall	90
2.2.7	Signal Analyzer.....	91
2.2.8	Carrier Under Carrier	93

Contents (cont'd)

		Page
	2.2.9 Query String.....	95
2.3	SNMP Interface.....	99
2.4	Specifications.....	100
	2.4.1 Single Port Decimator.....	100
	2.4.2 Multiport Decimator.....	102
2.5	Maintenance	104
	2.5.1 Cleaning.....	104
	2.5.2 Calibration	104
	2.5.3 Product Support.....	104
3.	Appendix A: Spectator Database Installation.....	105
	3.1 Overview	105
	3.2 Architecture.....	105
	3.3 Summary of Installation Steps.....	106
	3.4 Install Docker Engine.....	106
	3.5 Run Docker Engine	108
	3.6 Download and Install Spectator Couch DB Service	110
	3.7 Make a Database Directory on your DB Server.....	111
	3.8 Start the Spectator Couch DB Service	111
	3.9 Verify the Spectator Couch DB Service is Running.....	112
	3.10 Run the Web UI DB Viewer and Configure as a Single Node.....	113
	3.11 Specify the Log Database Name in Spectator UI Configuration	116
	3.12 Run Spectator Carrier Monitoring	116

Contents (cont'd)

	Page
3.13 <i>Stop the Spectator Couch DB</i>	116

Figures

	Page
3-1 <i>Spectator / Detector Database Deployment</i>	105
3-2 <i>Windows Users and Groups</i>	107
3-3 <i>Couch DB Web UI Login</i>	113
3-4 <i>Configuring Single Node</i>	114
3-5 <i>Configuring Single Node Continued</i>	114
3-6 <i>Replicate Data (No need to replicate)</i>	115

1. Operations Guide

Note: This product is developed by the Calian Advanced Technologies division headquartered in Saskatoon, SK, herein after referred to as Calian.

This section describes the general operation of the Decimator. It includes a description of common activities for the Decimator and describes features and configurations that are specific to either the Single Port or Multiport Decimator. Section 2.0 provides detailed reference information.

The Decimator product consists of the following:

- One of the following:
 - Single Port Decimator
 - Decimator card PCI Express x1 (PCIe), or
 - Portable Decimator
 - Multiport Decimator
 - 4 port, or
 - 8 port
- Power cord
- Rubber feet for use on a bench top

Refer to section 2.1 for installation instructions for the Decimator.

1.1 Single Port Decimator

The Single Port Decimator installs in a computer's PCI Express x1 (PCIe) slot or in a portable enclosure. Note that the card does not work in a PCI slot. Alternately, it can be installed in any suitable enclosure, mounted on standoffs and powered from +12 and +3.3VDC or +5 VDC. When installed in a PCIe slot in a computer, you will need a power cable (supplied) to connect to the ATX power supply of your computer using the peripheral power supply connector.

The Decimator will load a graphical user interface (GUI) on your PC when you reference it from a browser such as Chrome, Edge, Internet Explorer, Safari, or Firefox. The GUI allows you to select which of the ports to use as the input to the Decimator and to make spectrum measurements, time domain measurements, and determine Decimator status.

Pictures of the Decimator D4 card and PC connector plates are shown in the following images. The Decimator card can be installed in a computer with a PCIe slot and accessed remotely via the Ethernet connection by a computer that has access to the same network. There are two Decimator card types with different connectors. Note that for the model with two Ethernet ports, the M&C Ethernet port should be used, not the Data Ethernet port as the Data Ethernet port is reserved for future use.

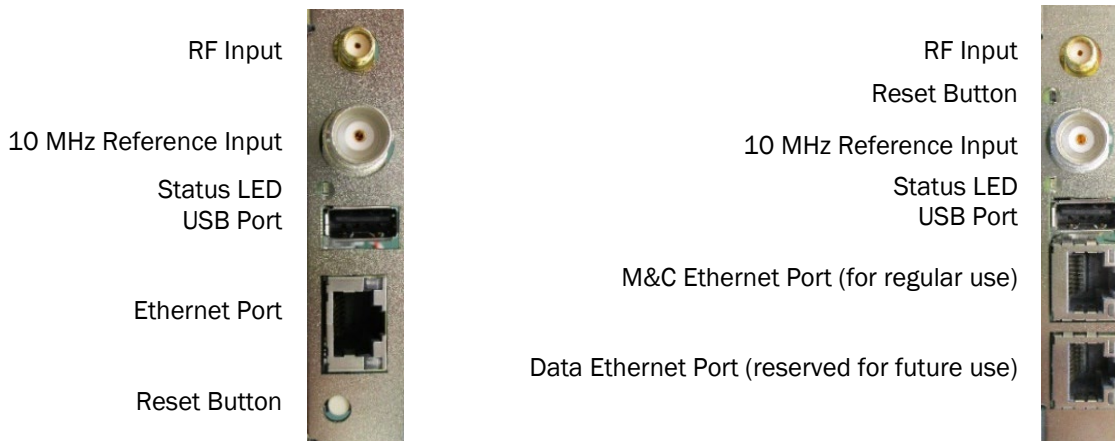

The following minimum capabilities are recommended for the host computer to accommodate the PCI Express x1 (PCIe) card:

- One PCI Express x1 (PCIe) slot
- Power supply capable of providing 25 W of steady state load to the card
- ATX power supply peripheral connection point

1.1.1 Connecting the D4 Card to an ATX Power Supply

If the PCIe connector is not able to adequately provide power to the Decimator D4 card, the D4 can be connected directly to the PC power supply. A power supply cable is provided with your card, but this section includes instructions to build your own cable (if desired).

To supply power from an ATX power supply 4-pin peripheral power cable, the +12V, ground and +5V pins must be connected to the D4.

The picture to the right shows an example of an ATX power supply peripheral power cable connector, with the table showing the pinout of the connector. Pin number 1 of the peripheral cable connector is usually yellow in colour and provides +12V. Pins 2 and 3 are ground pins and are usually black wires. Pin number 4 usually has a red wire and provides +5V.

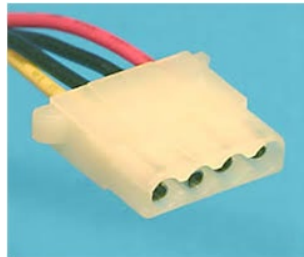

Pinout		
Pin number	Wire color	Description
1	yellow	+12 volts
2	black	ground
3	black	ground
4	red	+5 volts

Three of the pins must be connected to the D4 card (shown below) at the JPWR power connector (circled in red). The mating connector for the JPWR connector is a Molex 0436450300. The D4 power connectors pins are labelled on the circuit card as 3.3V/5V, GND, and 12V. Connect pin 1 of the peripheral connector to the D4 pin labelled 12V. Connect pin 4 of the peripheral connector to the D4 pin labelled 3.3V/5V. Either pin 2 or 3 of the peripheral connector can be connected to the D4 GND connector. Use 20AWG wires for interconnection.



1.2 Multiport Decimator

The Multiport Decimator product consists of a 1U rack-mount chassis containing a Decimator card and a multiport switch card. The Decimator will load a graphical user interface (GUI) on your PC when you reference it from a browser such as Chrome, Edge, Internet Explorer, Safari, or Firefox. The GUI allows you to select which of the ports to use as the input to the Decimator and to make spectrum measurements, time domain measurements, and determine Decimator status.

The Multiport Decimator front and rear panels are shown below. The Decimator can be installed in a standard 19-inch equipment rack and accessed remotely via the Ethernet connection by a computer that has access to the same network.



1.3 Client Computer

The following minimum capabilities are recommended for the client computer:

- 2.3 GHz Processor (or better)
- 8 GB of RAM (or better)
- Operating system that supports a web browser as listed below
- Web browser such as Chrome, Edge, or Safari, with minimum versions as summarized below:

Chrome	Edge	Safari
119	119	17.1

- Ethernet connection available for the Decimator to connect to the computer.

2. Reference Manual

This section is a detailed reference for the capabilities of the Decimator.

2.1 Decimator Installation

The Decimator can be operated on a tabletop but is usually installed in a standard 19-inch equipment rack. The rubber feet should be removed prior to installation in a rack. The RF inputs should not be directly connected to an outdoor antenna unless appropriate local electrical protection procedures are followed. Typically, a low noise amplifier (LNA) or similar device should be connected between the antenna and the Decimator.

The Decimator can be set up as either dedicated or shared access. With dedicated access, an Ethernet cable is connected directly between the client computer and the Decimator. In this configuration, only the client computer can access the Decimator. With shared access, an Ethernet cable is connected between the Decimator and a hub or switch. In this configuration, any computer on the network can access the Decimator.

No software needs to be installed on the client computer in order to use the Decimator from a browser because the graphical user interface (GUI) will automatically be loaded by the web browser. Direct access to the API requires user-written API software.

2.1.1 Decimator Setup

The following steps should be followed when setting up your Decimator:

1. Unpack your Decimator and position it in an area where it will be near your network and RF feeds.
2. Connect a LAN cable from the Decimator to your network.
3. Connect your RF input(s) from the LNA(s) originating at the antenna to your Decimator.
4. Connect your power cord from the Decimator to your power source.
5. Wait two minutes to allow it to boot up.
6. Navigate to the Decimator Configuration to configure it the way you want (see section 2.2 and section 2.2.3).
7. Either start programming the API (see section 2.2.3.7) or view the GUI (see section 2.2).

2.1.2 GUI Connections

The Decimator supports a modern web GUI and the legacy socket API for backwards compatibility. These interfaces are designed to allow up to 10 remote connections simultaneously. However, multiple connections will affect the speed at which the Decimator can make measurements, as measurement requests on all connections are handled on a first come first served basis. The resultant delays may require the *Connection Timeout* to be increased.

2.1.3 Self-Signed Certificate Warning

The Decimator uses secure HTTP protocol (HTTPS). It uses encryption certificates to operate. The initial Decimator comes with a 'self-signed' certificate. The initial web GUI connection by a user results in a warning that the connection is not trusted.

THIS IS NORMAL.

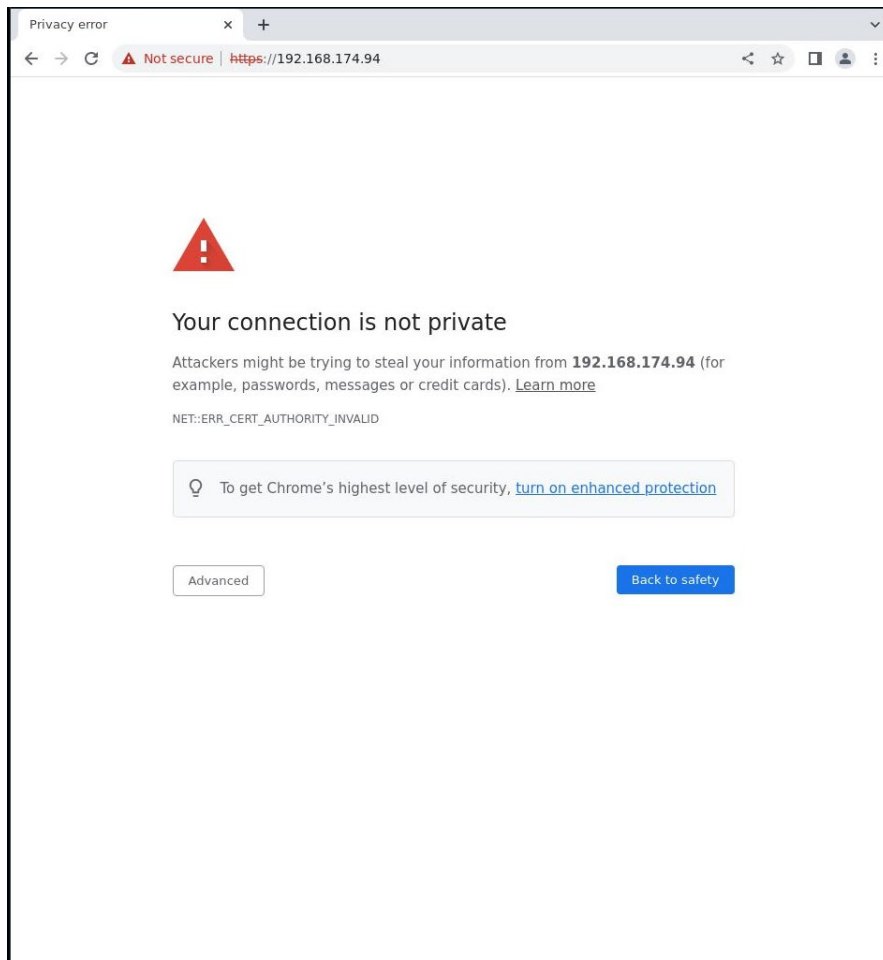

Select the 'Advanced' button.

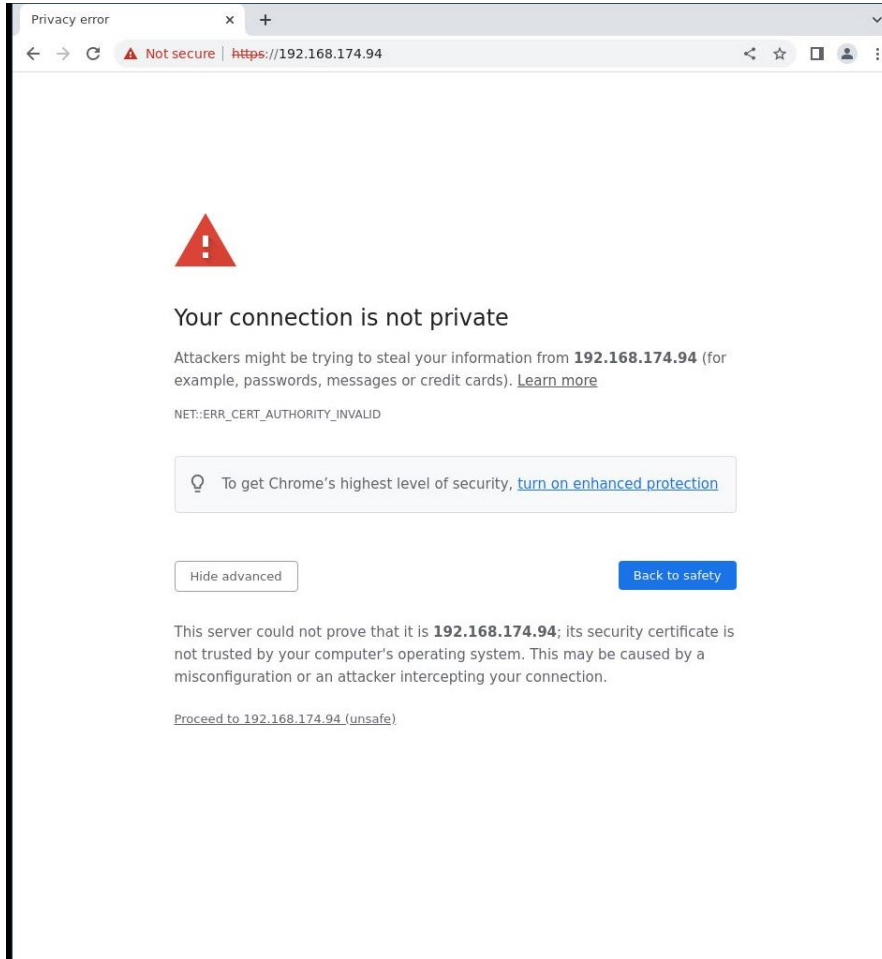

Select 'Proceed to (unsafe)'. You will then proceed to the Decimator's web interface. The warning can be suppressed by installing a custom certificate; see Configuration -> Certificates page

2.1.4 Input Signal Considerations

The input to the Decimator must be in the range listed in section 2.4. Note that the input can be limited by an external filter to the band of interest within this range in order to avoid reducing the signal-to-noise ratio of the instrument. The more broadband noise allowed into the Decimator, the lower the dynamic range available for the Decimator to use.

The total power in the full L-band range should not exceed the input power level specification for the Decimator. A band-pass, high-pass, or low-pass RF filter suitable for 75 Ω or 50 Ω applications may be used on the input to the Decimator.

2.1.5 10 MHz Reference Considerations

The Decimator uses a 10 MHz reference as a frequency reference. Note that frequencies reported will be limited in accuracy and phase noise by the choice of 10 MHz reference. The onboard frequency reference is accurate to ± 2.6 ppm and is selected by default. An external reference will typically provide better accuracy.

The external frequency reference must be selected through the GUI or the API. The setting will remain selected until you close the connection.

2.1.6 Safety Considerations

This user manual must be reviewed before installation and operation of the Decimator. Failure to do so can result in damage to the unit or personal injury. If the equipment is used in a manner not specified by the manufacturer, the protection provided by the equipment may be impaired. Heed all warning symbols.



CAUTION Symbols can be found within this user manual or on the instrument. The **CAUTION** symbol denotes a hazard. It calls attention to a situation that could result in personal injury or damage to the product. Do not proceed beyond a **CAUTION** until the indicated conditions are fully understood.

Additional symbols found on the unit are shown below.



The **CAUTION, RISK OF ELECTRICAL SHOCK** symbol indicates high voltages may be present which can cause injury or death.

Korean Certification (KCC):

사용자안내문

사 용 자 안 내 문
이 기기는 업무용 환경에서 사용할 목적으로 적합성평가를 받은 기기로서 가정용 환경에서 사용하는 경우 전과간섭의 우려가 있습니다.

※ 사용자 안내문은 "업무용 방송통신기자재"에만 적용한다.

2.2 Web GUI

The Decimator provides a GUI that can be displayed using a web browser such as Chrome, Edge, Internet Explorer, Safari, or Firefox.

To connect to the GUI, launch the web browser and enter the URL to connect, prepended by "https://". When the D4's IP address is known, the URL is the IP address. For example, if the D4's IP is set to 192.168.10.10, the access URL is https://192.168.10.10. See section 2.2.3.1.1 for the default IP settings. When Avahi is enabled (see section 2.2.3.7), the D4 can be accessed using the hostname. For example, if the hostname is decimatord4-1234, the URL will be https://decimatord4-1234.local. The hostname can be set via the Network Configuration page (see section 2.2.3.1.2).

Note that HTTPS must be used to connect. The Decimator does not support HTTP.

2.2.1 Launch

The GUI allows interactive use of the Decimator for general-purpose spectrum analysis. When launched, the Decimator initially displays the *Spectrum* application, which is described in further detail in section 2.2.4. The following figure shows the main GUI for the Decimator.

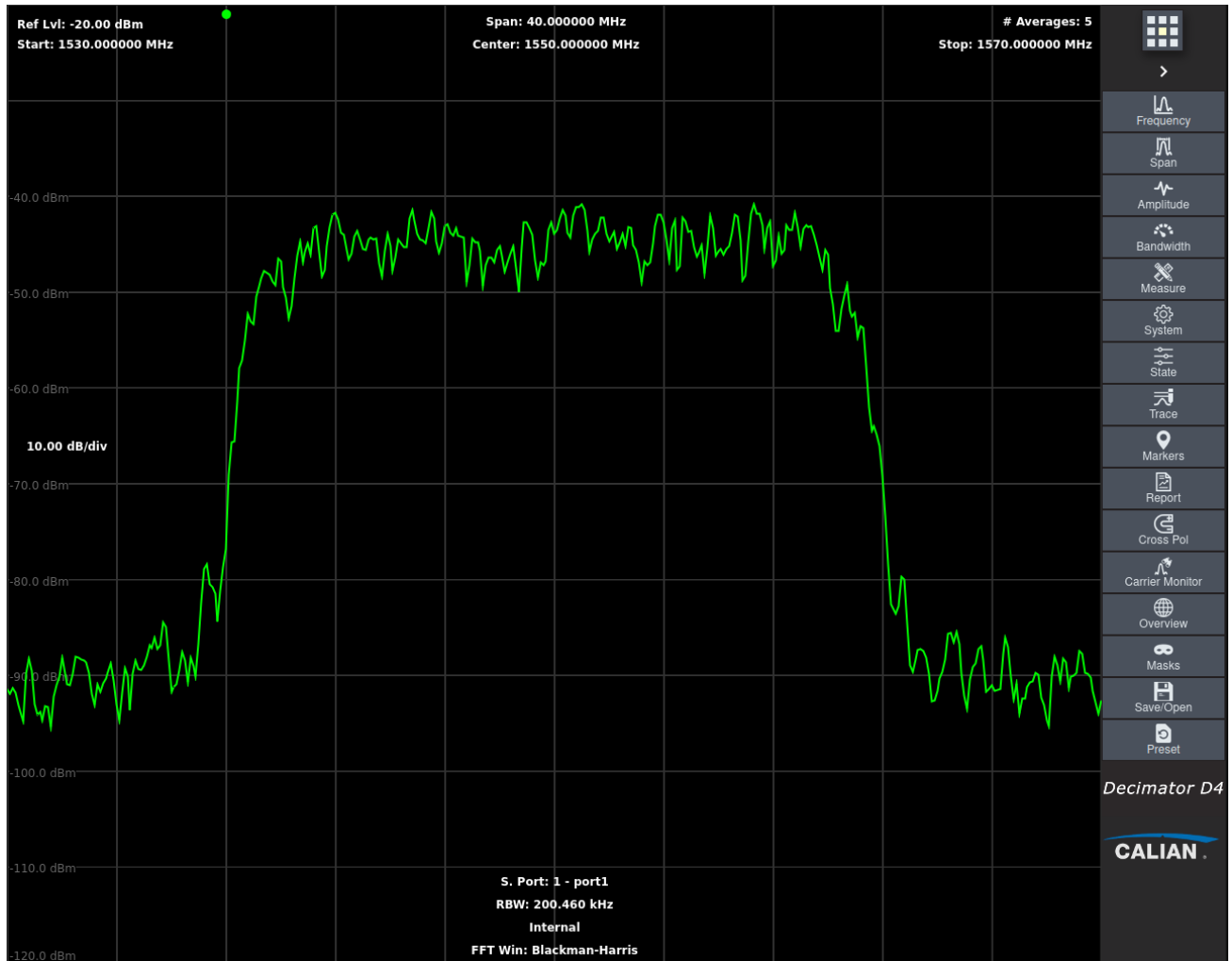

The display is divided into these areas:

- Spectrum display on the left side main area.
- Control buttons on the right side column. At the top right is the apps button.

2.2.2 Apps

The apps button is found on the top right corner of every screen in the Decimator GUI. It is used to navigate between features of the Decimator.

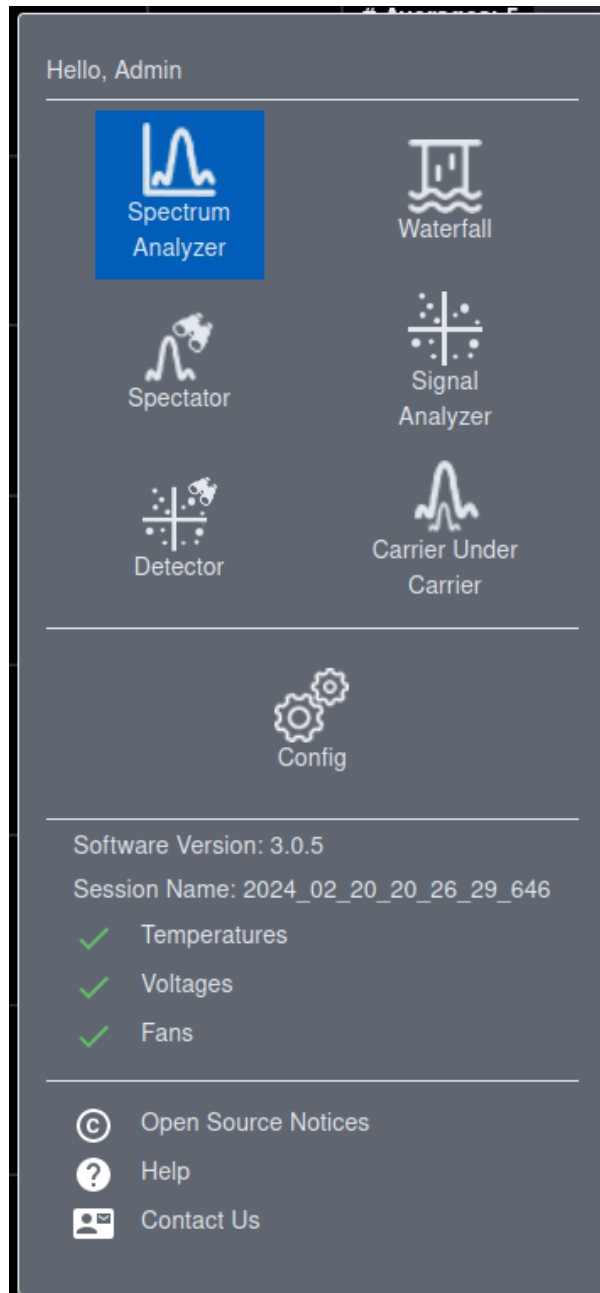

The center square of the button displays an indicator of the Decimator status.

When the Decimator is in a healthy state, the indicator is colored green.



Red indicates there is an issue that requires attention.



The dialog displayed when the apps button is clicked consists of these areas:

- User identification
- Applications
- Configuration
- Status information
- Menu items for open source notices, Calian contacts, and user help

The user identification area displays the current user sign-in.



Hello, DefaultUser

The applications area displays the user applications, with the application you are currently using highlighted in blue. When an application requires a license and that license is missing, the corresponding button is disabled. Hovering the mouse over or clicking a disabled button displays a tool tip that details that the application is disabled and the reason it is unavailable. This tool tip also provides a link that directs you to instructions for obtaining the required license.

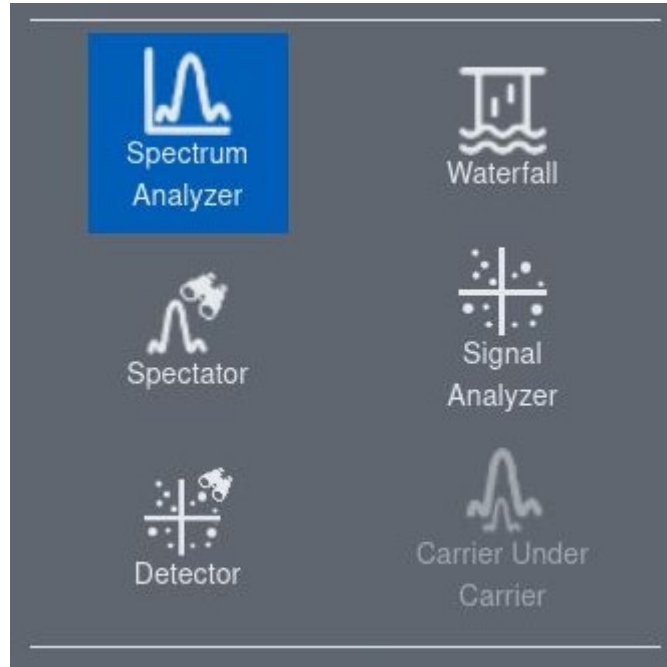

The available applications are described in the following table.

Application	License?	Users	Description	Section
<i>Configuration</i>	No	Admin	Configure the Decimator. (Operators can access Calibration.)	2.2
<i>Spectrum</i>	No	All	Run measurements on the Decimator.	2.2.4
<i>Spectator</i>	Yes	All	Monitor created measurements and view spectrum	2.2.5
<i>Detector</i>	Yes	All	Monitor created measurements and view constellation	2.2.5
<i>Waterfall</i>	No	All	Displays measurements as power vs frequency over time.	2.2.6
<i>Signal Analyzer</i>	No	All	View constellation and other plots of the measurements.	2.2.7
<i>Carrier Under Carrier</i>	Yes	All	View plots of a modulated carrier, the ideal reconstructed carrier, and the difference carrier showing distortions or interfering signals.	2.2.8

The configuration area has a button leading to the Decimator *Config* page. See section 2.2.3 for details. You must have an account with administrator permission to be able to log in to the *Config* page.

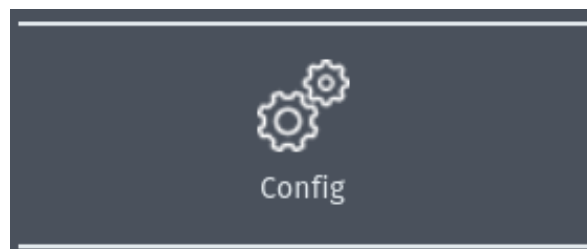

The status information area provides details about your current session and the version you are using, along with status of the Decimator temperature sensors, voltages, and fans. Click this area to open the status dialog (same as *Status* under the *System* menu).

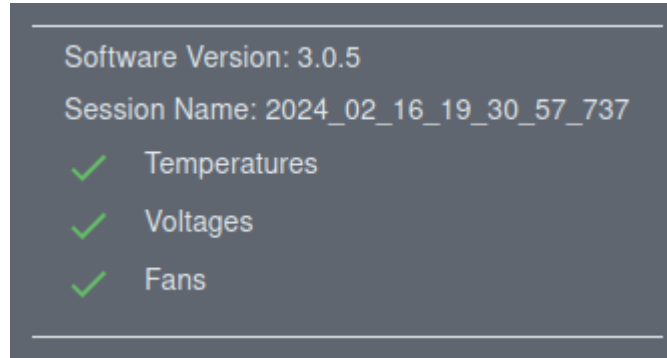

The bottom area of the dialog allows you to view open source notices, Calian contact information, and help (this user manual).

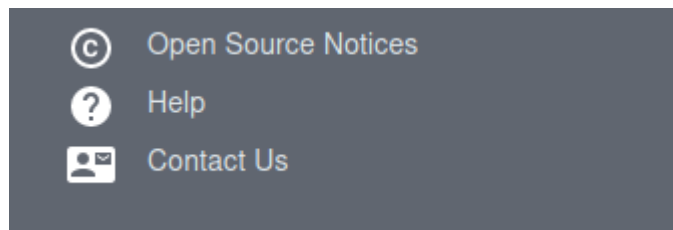

2.2.3 Configuration

The Decimator has a configuration page used to modify the network configuration, calibration files, port names, and licenses. To access the Decimator configuration:

1. Navigate to <https://192.168.10.10>
2. The Decimator GUI will be displayed.

3. Click the apps button  at the top right corner. The spectrum will be highlighted in blue, as it is the application currently visible.

4. Click the *Config* button . If you are not already logged in, this will display the *D4 Config Log In* dialog.

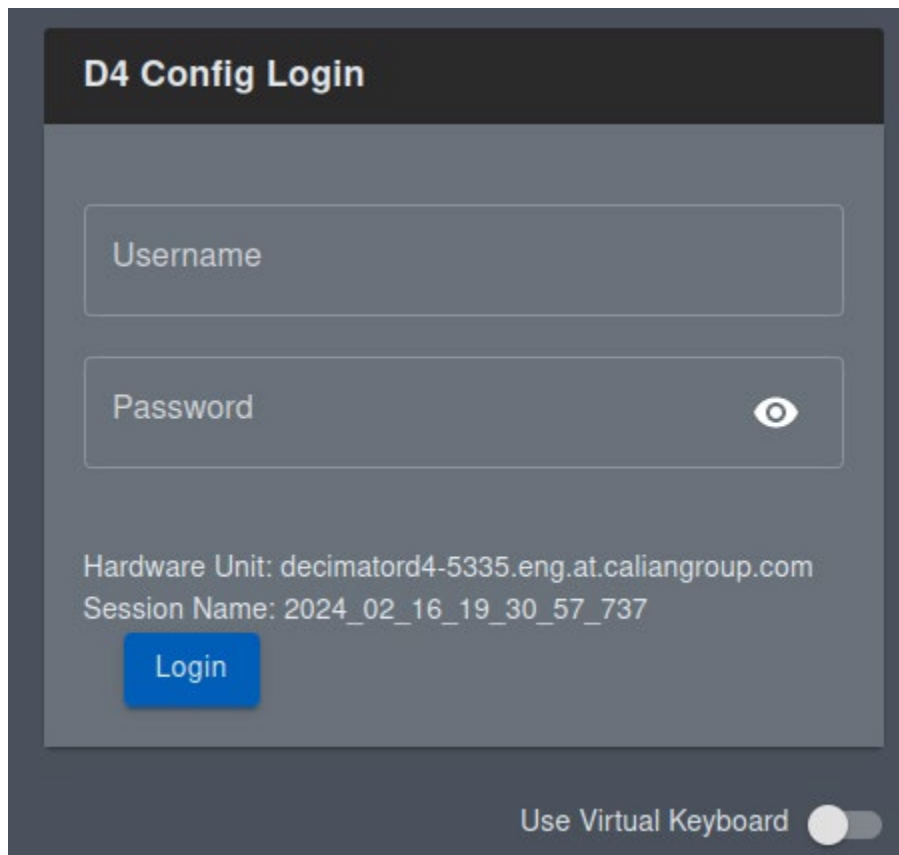

The screenshot shows a dark-themed dialog box titled "D4 Config Login". It contains two input fields: "Username" and "Password". The "Password" field has a toggle icon (an eye) to the right of it. Below the input fields, there is text indicating the hardware unit and session name: "Hardware Unit: decimator4-5335.eng.at.caliangroup.com" and "Session Name: 2024_02_16_19_30_57_737". A blue "Login" button is positioned below the session name. At the bottom right of the dialog, there is a toggle switch labeled "Use Virtual Keyboard".

The title in the *D4 Config Log In* dialog indicates you are trying to access the Decimator configuration. This dialog also displays information about the Decimator and your session at the bottom.

The factory default user name and password for the administrator account for the Decimator configuration is:

- User name: Admin
- Password: Admin

After you sign in, the Decimator *Config* page will be displayed, where you can change settings for the following:

- Network
- User accounts
- Calibration
- Port names
- Certificates
- License
- Remote access
- Illuminator
- Firmware
- Restart
- Recent Connections
- Open Source Notices
- Contact Us
- Help
- Logout

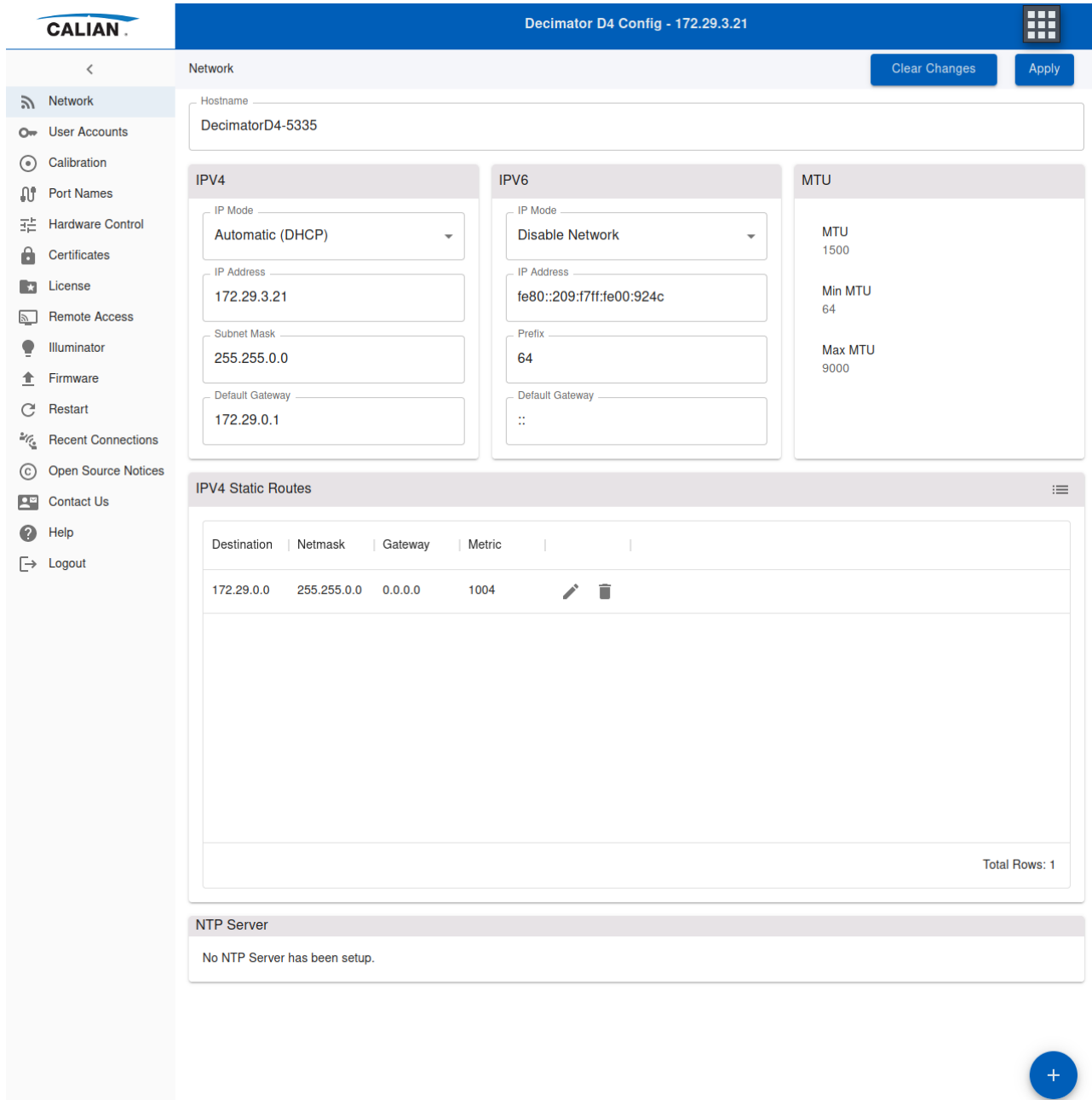

2.2.3.1 Network

The *Network* tab is used to configure the network for IPv4 or IPv6, static routes for IPV4, as well as NTP server settings, and the hostname.



The screenshot shows the 'Decimator D4 Config - 172.29.3.21' web interface. The 'Network' tab is active, displaying the following configuration options:

- Hostname:** DecimatorD4-5335
- IPv4 Configuration:**
 - IP Mode: Automatic (DHCP)
 - IP Address: 172.29.3.21
 - Subnet Mask: 255.255.0.0
 - Default Gateway: 172.29.0.1
- IPv6 Configuration:**
 - IP Mode: Disable Network
 - IP Address: fe80::209:f7ff:fe00:924c
 - Prefix: 64
 - Default Gateway: ::
- MTU Configuration:**
 - MTU: 1500
 - Min MTU: 64
 - Max MTU: 9000
- IPv4 Static Routes:**

Destination	Netmask	Gateway	Metric		
172.29.0.0	255.255.0.0	0.0.0.0	1004		

Total Rows: 1
- NTP Server:** No NTP Server has been setup.

A blue '+' button is visible in the bottom right corner of the interface.

2.2.3.1.1 Default Network Settings

The Decimator network configuration factory defaults are:

- IP address = 192.168.10.10
- Netmask = 255.255.255.0
- Gateway = 0.0.0.0 (unspecified)

The reset switch on the rear of the Decimator can be used to restore the Decimator's network configuration and API ports to the defaults. Any installed calibration or license files will remain unchanged. The procedure to restore the factory default settings is as follows:

1. Remove power to the Decimator.
2. Locate the reset switch on the rear of the Decimator chassis or on the connector plate by the 10 MHz REF connector as shown by the red circle in the figure below. Using a paperclip or similar instrument, depress the switch and hold. There is very little travel in the switch actuator, so the switch should be pressed gently.

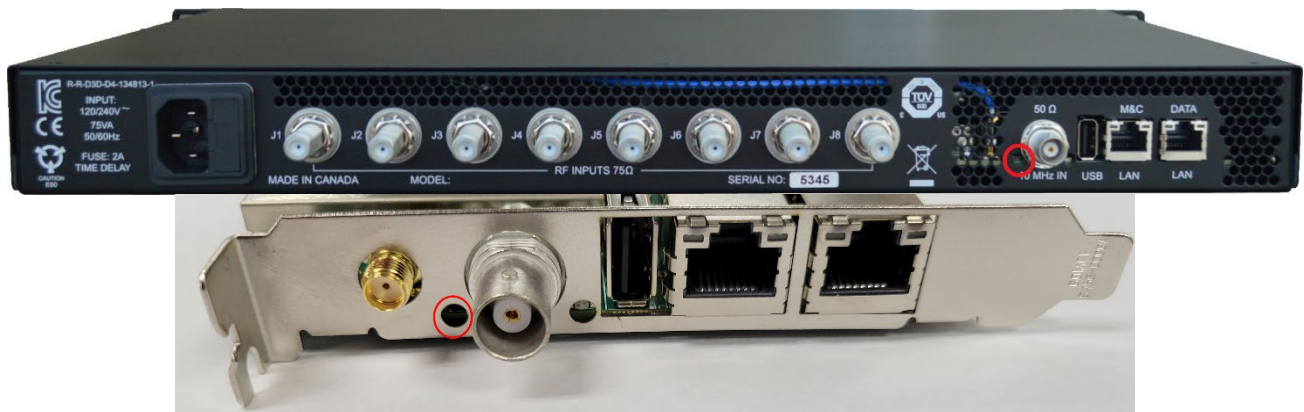

3. Apply power to the Decimator and allow two minutes for the Decimator to initialize.
4. Stop depressing the reset switch.
5. The network configuration should now be restored to factory defaults.

2.2.3.1.2 Hostname

The Decimator's hostname may be set by entering the desired hostname into the hostname field, then clicking *Apply* at the top of the page. The Decimator will need to be reset in order to activate the change.

2.2.3.1.3 IP Settings

You can configure the IP settings for both IPv4 and IPv6. Configurable settings include:

- IP mode
- IP address
- Netmask
- Default gateway

The *IP Mode* drop down has the following options:

- Automatic (DHCP)
- Static
- Disable network

In order to configure the IP version the Decimator is to use, set one of the *IP Mode* fields to *Automatic* or *Static* and the other to *Disable Network*. Ensure the other fields are filled in and then apply the changes. Navigate to the *Reset* menu and click the *Soft Reset* button to activate the changes.

The Maximum Transfer Unit (MTU) is the maximum size of network packets used on the network. The default MTU is 1500, consistent with typical Ethernet/IP devices. Larger MTU values increase the efficiency of network transfer at the cost of reduced error correction. The MTU can be increased, however, to take effect all network devices in the path must support the larger MTU. The Decimator is tested with MTU up to 4500. The fields on the Decimator page are informational and report the minimum and maximum supported MTUs reported by the network, and the current MTU setting. The MTU can be set via the DHCP server.

2.2.3.1.4 IPV4 Static Routes

You can configure the static route settings for both IPv4. Configurable settings include:

- Destination
- Netmask
- Gateway
- Metric

You can add, edit or delete static routes. Clicking the Add button () and selecting *Add Static Route* displays the following dialog:

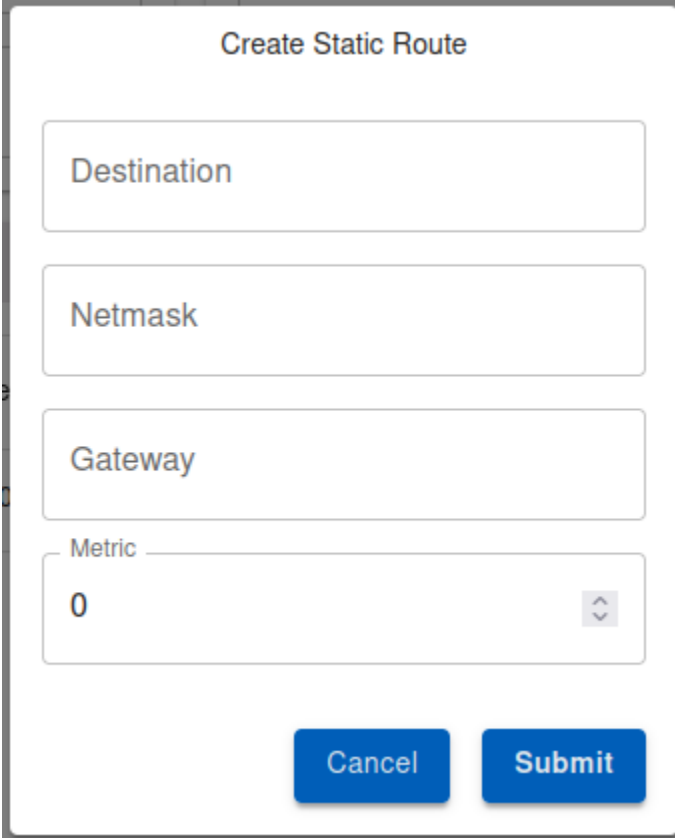

The dialog box is titled "Create Static Route" and contains the following fields and buttons:

- Destination:** A text input field.
- Netmask:** A text input field.
- Gateway:** A text input field.
- Metric:** A dropdown menu with "0" selected and a small up/down arrow icon on the right.
- Buttons:** "Cancel" and "Submit" buttons at the bottom right.

2.2.3.1.5 NTP Settings

The Decimator does not have a battery backed real time clock, and does not track the time through a restart or power outage. The Decimator can synchronize time to an external Network Time Protocol (NTP) server. Setting the time greatly enhances the carrier monitoring emails, as the emails include the time of the event and an accurate time simplifies correlating the event with other activities in the system. Setting the time is required when using the Decimator with Illuminator. Setting the time is also required when using custom secure socket certificates.

You can set the NTP server IP address by clicking the Add button () and selecting *Add NTP Address* in the NTP Settings panel. Once created, the IP address can be edited using the following dialog.

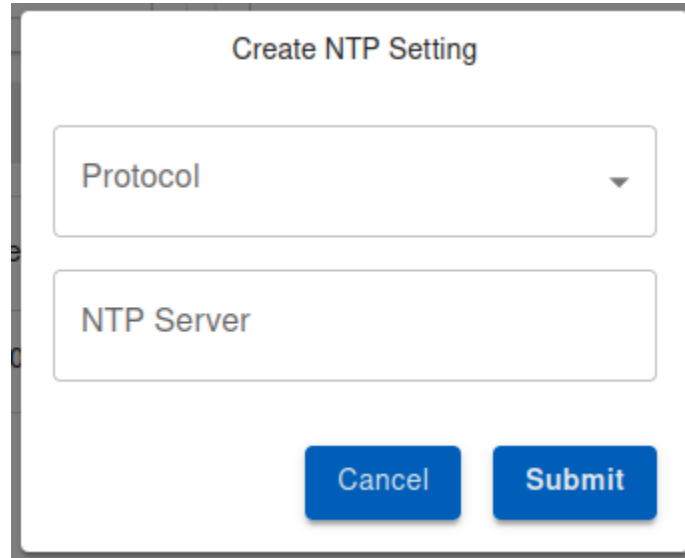

The image shows a dialog box titled "Create NTP Setting". It contains two input fields: a dropdown menu labeled "Protocol" and a text input field labeled "NTP Server". At the bottom of the dialog, there are two blue buttons: "Cancel" and "Submit".

Enter the NTP server IP address and select the protocol as either *IPV4* or *IPV6* as applicable. Only one NTP server can be specified.

2.2.3.2 User Accounts

The *User Accounts* tab is used to manage the accounts used to access the Decimator. There must always be at least one active *Admin* account.

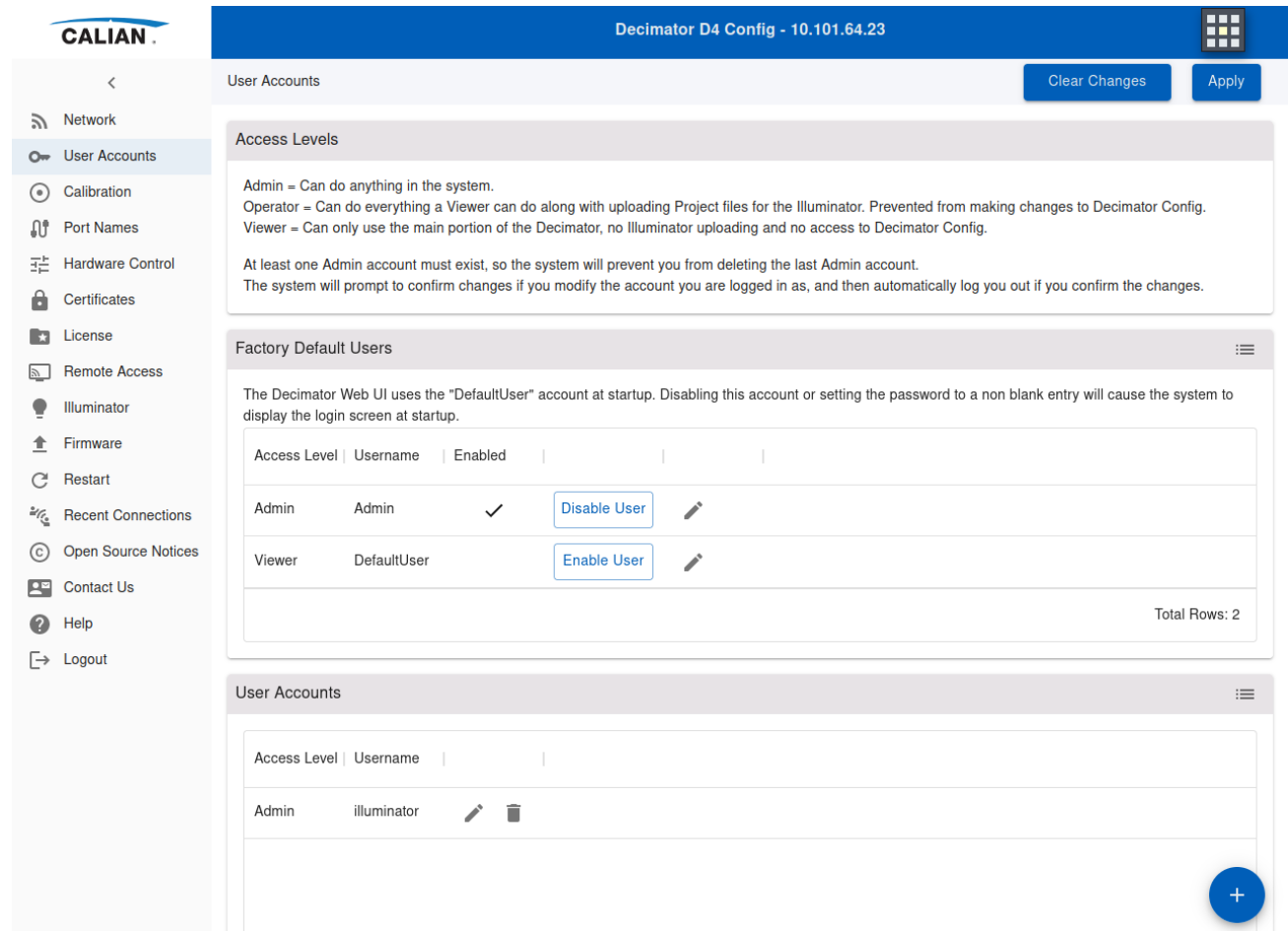

The screenshot shows the 'User Accounts' configuration page. The top navigation bar displays 'Decimator D4 Config - 10.101.64.23'. The left sidebar contains various system settings. The main content area is divided into three sections:

- Access Levels:** Defines roles:
 - Admin = Can do anything in the system.
 - Operator = Can do everything a Viewer can do along with uploading Project files for the Illuminator. Prevented from making changes to Decimator Config.
 - Viewer = Can only use the main portion of the Decimator, no Illuminator uploading and no access to Decimator Config.
- Factory Default Users:** A table listing default users with 'Disable User' and 'Enable User' buttons.

Access Level	Username	Enabled		
Admin	Admin	✓	Disable User	
Viewer	DefaultUser		Enable User	
- User Accounts:** A table for managing user accounts.

Access Level	Username		
Admin	illuminator		

(Note: factory default user accounts cannot be deleted, they can only be deactivated.)

2.2.3.2.1 Factory Default Users

This panel allows you to configure the factory default accounts that come installed on the Decimator. There are two factory default accounts:

- *Default User* account used for viewing the GUI from startup without having to log in. See *Bypassing the Login Screen at Session Startup* for details.
- *Admin* account used to configure the Decimator.

These accounts can be disabled and their passwords changed, but they cannot be deleted or have their access levels modified.

The administrator can enable and disable the factory default accounts using the buttons next to the *Enabled* column. An enabled account will have a check mark in the enabled column. Disabling these accounts makes them inactive, such that when a user tries to sign in with the correct user name and password for the account, the user will receive an invalid access response. To commit the change click *Apply* at the top right of the tab.

The *Edit* button allows you to change the passwords for each account.

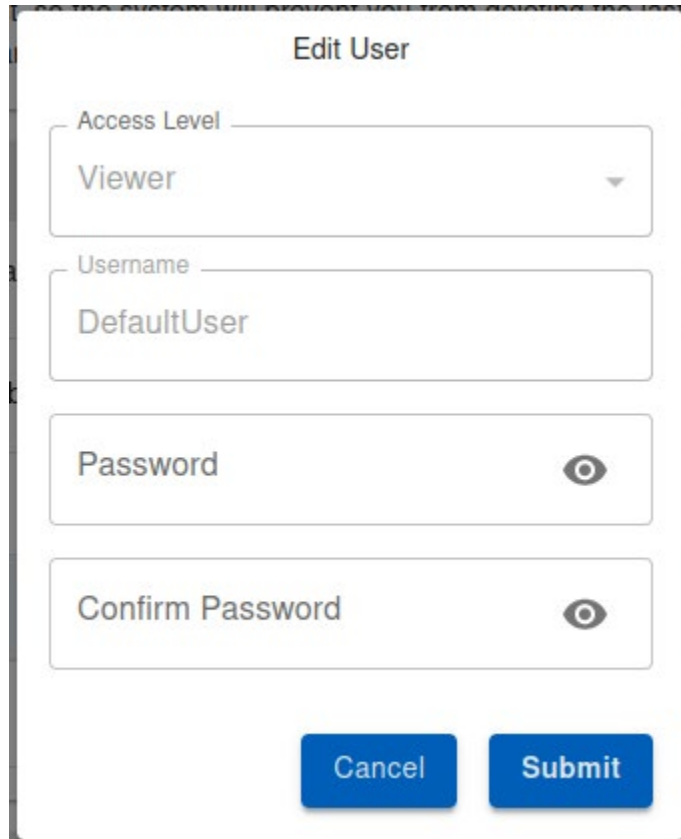

To commit the change click *Apply* at the top right of the tab.

2.2.3.2.1.1 Bypassing the Login Screen at Session Startup

To allow all Decimator GUI session startups to not have to login, enable the DefaultUser account by pressing the Enable User button:

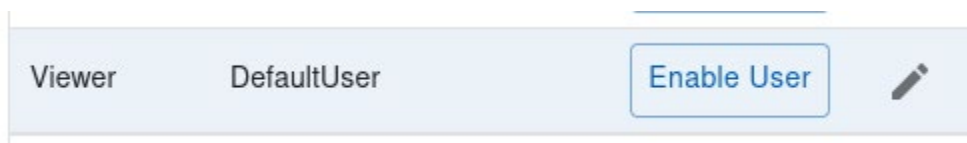

2.2.3.2.2 User Accounts

The *User Accounts* panel lists all of the custom user accounts that have been created for the Decimator. It allows administrators to add, edit, and delete accounts.

2.2.3.2.2.1 Add User

To add a new user to the Decimator, click the *Add User* button (), located at the bottom of the screen. A dialog will appear requesting the access level, user name, and password.

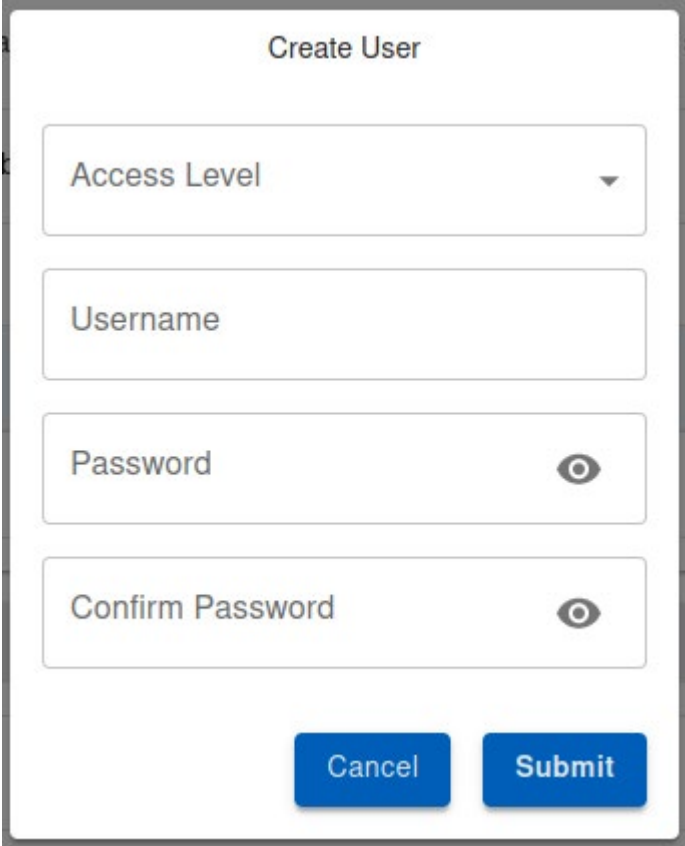

The image shows a 'Create User' dialog box with the following fields and buttons:

- Access Level**: A dropdown menu.
- Username**: A text input field.
- Password**: A text input field with a toggle icon (eye) to the right.
- Confirm Password**: A text input field with a toggle icon (eye) to the right.
- Cancel**: A blue button.
- Submit**: A blue button.

Once the data is entered, click *Submit* to validate the entries. All fields must be filled in and the passwords must match. If an inconsistency is found, an error message will be displayed and the dialog will remain open. Submitting a valid form will add a new user to the *User Accounts* display. The row will remain highlighted in yellow until the *Apply* button is clicked at the top right of the tab.

2.2.3.2.2 Edit User

To edit a user, click the *Edit* button on the row to be edited. A dialog will appear with the access level and user name filled in. The user name field will be disabled.

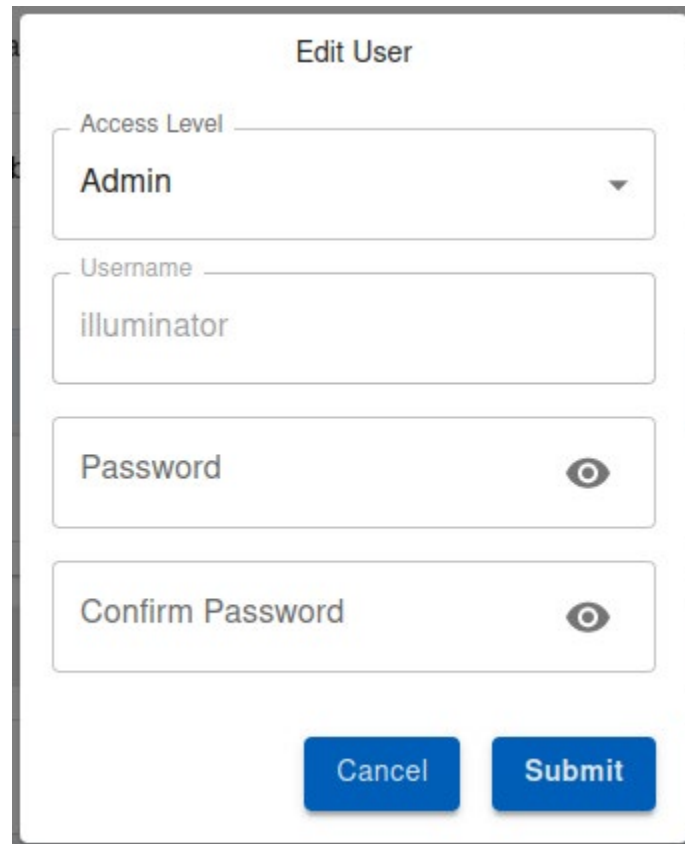

The screenshot shows a dialog box titled "Edit User". It contains the following fields and controls:

- Access Level:** A dropdown menu with "Admin" selected.
- Username:** A text input field containing "illuminator".
- Password:** A text input field with a toggle icon (an eye) to the right.
- Confirm Password:** A text input field with a toggle icon (an eye) to the right.
- Buttons:** "Cancel" and "Submit" buttons at the bottom.

You can change the access level and password and then update the account. Click the *Submit* button to commit the changes. The Decimator ensures that a modified access level does not remove the last active administrator account. A warning message will be displayed if the Decimator cannot allow the change to continue. To commit the change click *Apply* at the top right of the tab.

2.2.3.2.3 Delete User

To remove a user from the Decimator, click the *Delete* button on the row of the user to be removed. To commit the change click *Apply* at the top right of the tab. The factory default accounts cannot be deleted, only disabled. At least one account with administrator privileges must always be enabled.

2.2.3.3 Calibration

The *Calibration* tab is used to:

- Manage the application of calibration to the ports.
- Add frequency converter offsets to measurements by the Decimator.

2.2.3.3.1 Port Calibration

For each port, a calibration file can be loaded to the unit. The calibration applies user defined power offsets to the measurement results. The calibration file can be used to incorporate the frequency response of external components connected to each port. The calibration does not affect the internal calibration of the Decimator.

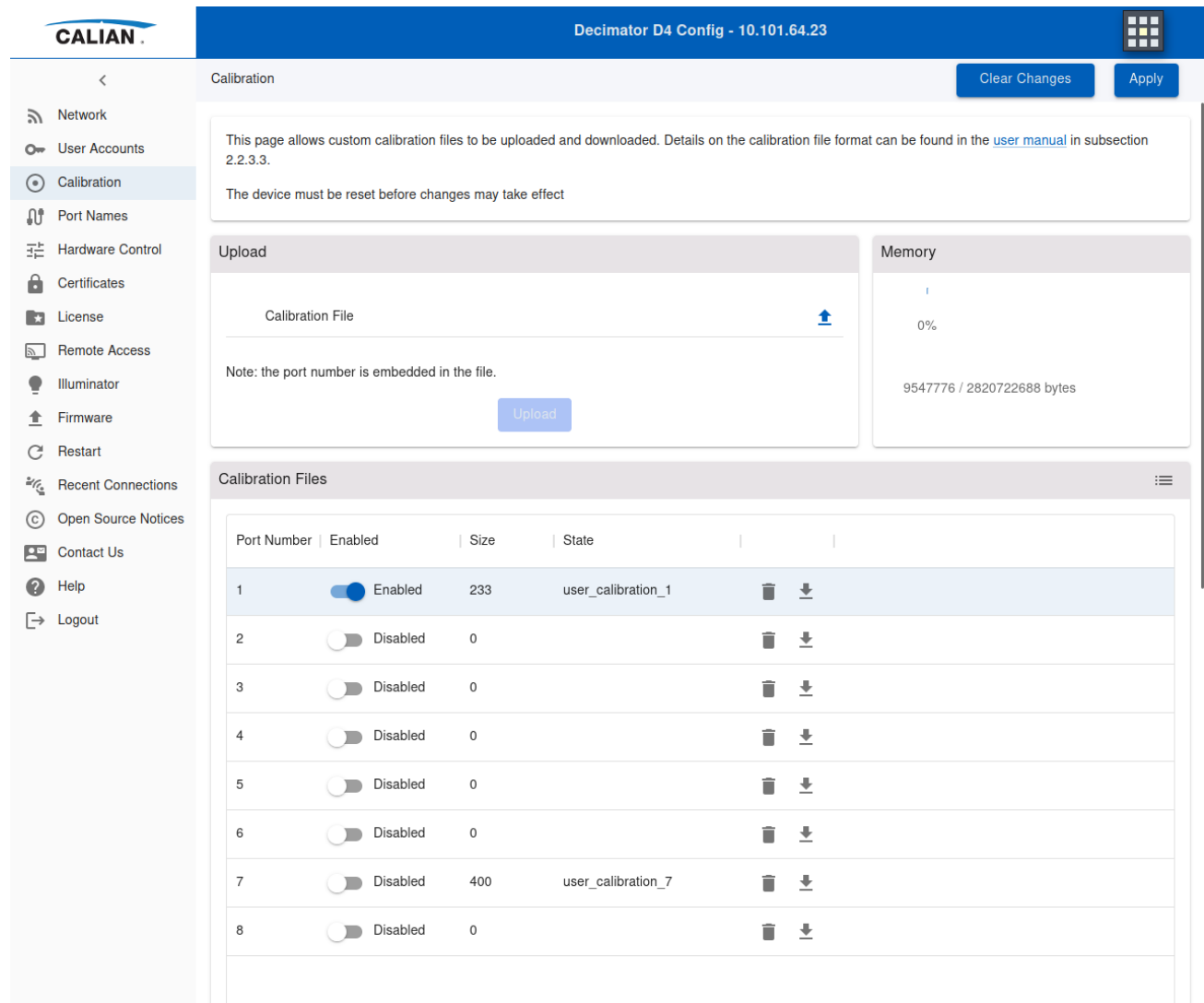

The screenshot shows the 'Decimator D4 Config - 10.101.64.23' web interface. The 'Calibration' tab is active, displaying instructions: 'This page allows custom calibration files to be uploaded and downloaded. Details on the calibration file format can be found in the [user manual](#) in subsection 2.2.3.3. The device must be reset before changes may take effect.' Below this is an 'Upload' section with a 'Calibration File' input field and an 'Upload' button. A note states: 'Note: the port number is embedded in the file.' To the right is a 'Memory' section showing '0%' usage and '9547776 / 2820722688 bytes' available. At the bottom is a 'Calibration Files' table:

Port Number	Enabled	Size	State		
1	<input checked="" type="checkbox"/> Enabled	233	user_calibration_1		
2	<input type="checkbox"/> Disabled	0			
3	<input type="checkbox"/> Disabled	0			
4	<input type="checkbox"/> Disabled	0			
5	<input type="checkbox"/> Disabled	0			
6	<input type="checkbox"/> Disabled	0			
7	<input type="checkbox"/> Disabled	400	user_calibration_7		
8	<input type="checkbox"/> Disabled	0			

A calibration file consists of two parts:

- Required File Information
- Frequency Response

The required file information lines begin with the '#' character. The lines should be in the specified order.

- **#Desc = *description string***
 - A text description of the calibration. One line of text starting after the equals sign.
- **#CalType = PORT**
 - Include this line in the calibration file.
- **#SerialNum = *serial number***
 - Specify the serial number of the Decimator that the calibration file is supposed to be on.
- **#LoMin = 0**
 - Include this line in the calibration file.
- **#LoMax = 0**
 - Include this line in the calibration file.
- **#Atten = 0**
 - Include this line in the calibration file.
- **#CalDate = *calibration date***
 - Specify the date the calibration was measured.
 - Date is specified in the format 'YYYY-MM-DD HH:mm:ss'
 - Year is a four-digit value
 - Month is a two-digit value in the range 01-12 (01 is January, 02 is February, ...)
 - DD is a two-digit value of the date in the range 01-31.
 - HH is the hour in the range 00-23
 - mm is the number of minutes in the range 00-59
 - ss is the number of seconds in the range 00-59
- **#Port = *N***
 - Specify which port on the decimator the calibration file should be applied to.
 - Single port decimators require "#Port = 1" to be specified.

- #Headings = Freq (Hz), Correction(dB)
 - Include this line in the calibration file.

The frequency response section consists of one or more frequency and power points. The power value in the calibration file is added to the power reading made by the Decimator. For example, if the Decimator reads 0 dBm at 975MHz on its input port and the port calibration specified “975000000,1.18”, the Decimator reports that the power at 975MHz is 1.18 dBm. The Decimator uses linear interpolation to estimate the power offset between frequencies specified in the calibration file. Frequency and power points must be sorted in ascending order by frequency.

Here is an example calibration file:

```
#Desc = Decimator D4 - RF In Calibration
#CalType = PORT
#SerialNum = 538
#LoMin = 0
#LoMax = 0
#Atten = 0
#CalDate = 2019-11-26 16:52:07
#Port = 1
#Headings = Freq (Hz),Correction(dB)
975000000,1.18
1000000000,-3.22
1200000000,-1.63
1400000000,-0.25
1600000000,0.39
1800000000,0.52
2000000000,0.62
2200000000,1.33
2400000000,2.50
2600000000,6.12
2800000000,7.15
3000000000,10.22
```

To enable or disable the use of the calibration file selected for each switch port, toggle the switch in the row of the port number. The switch will be green and positioned to the right when enabled. Click the *Apply* button at the top right corner to submit the changes.

To upload a calibration file, click the *Choose file* button () in the *Upload* panel. A file selection dialog will then be displayed. Select the desired file and the file name will then appear beside the button. Click the *Upload* button to submit the chosen file. The *Size* and *State* fields for that row will then be updated to the file's size and name. The *Download* button will also be enabled.

To delete a calibration file, click the *Delete* button on the row of the applicable port. If there is no file for that row, a notification dialog will be displayed. When there is a file, the *Size* and *State* will then return to the default values of 0 and blank. The *Memory* field will be updated to reflect the changes.

To download a calibration file to the *Downloads* folder, click the *Download* button on the desired row.

2.2.3.3.2 Downconverter Frequencies

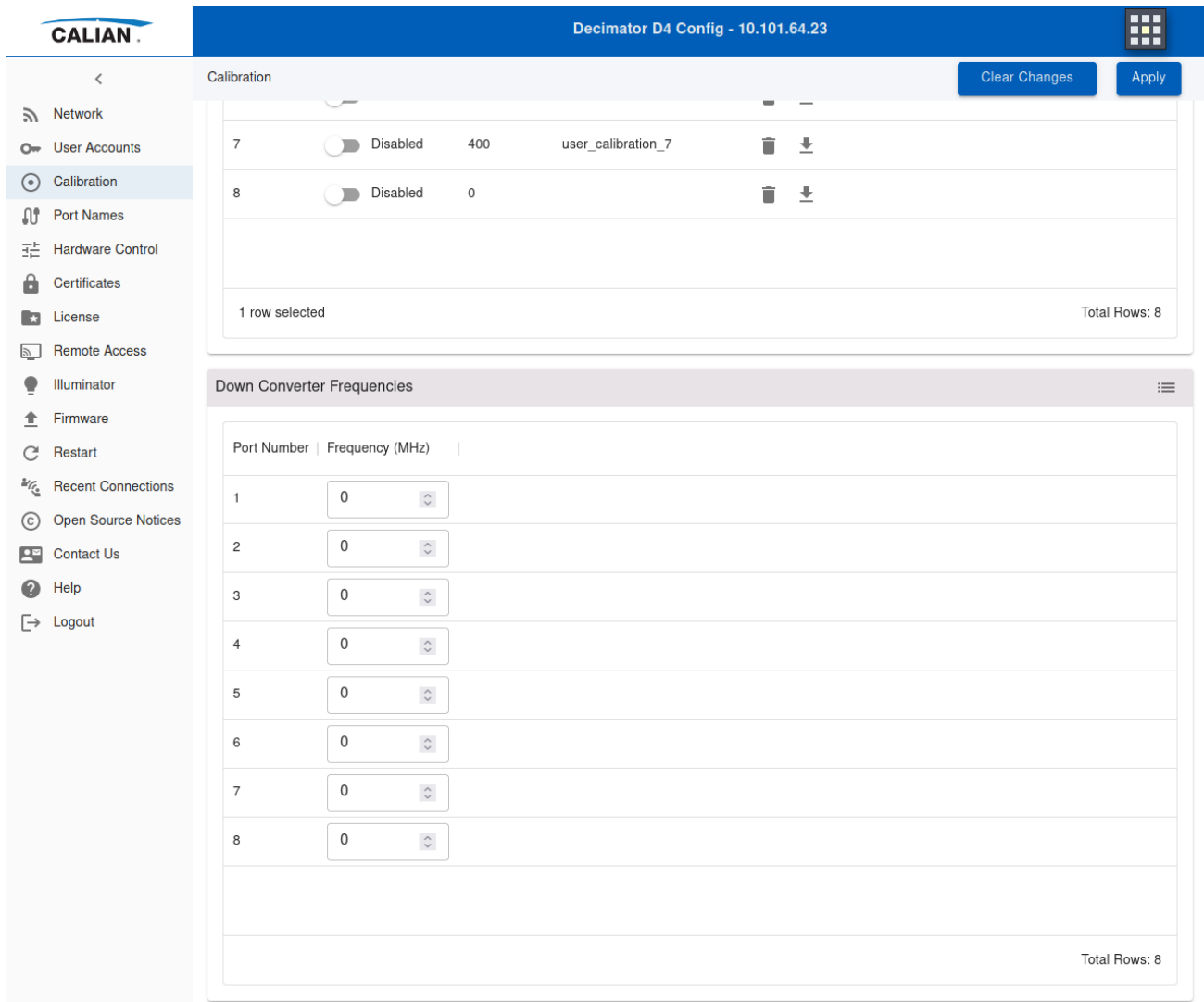

The screenshot displays the web interface for Decimator D4 Config at IP 10.101.64.23. The left sidebar contains navigation options such as Network, User Accounts, Calibration, Port Names, Hardware Control, Certificates, License, Remote Access, Illuminator, Firmware, Restart, Recent Connections, Open Source Notices, Contact Us, Help, and Logout. The main content area is divided into two sections:

Calibration: This section shows a table with columns for Port Number, Status, Frequency, and Name. Two rows are visible, both with a 'Disabled' status. Row 7 has a frequency of 400 and a name of 'user_calibration_7'. Row 8 has a frequency of 0. Below the table, it indicates '1 row selected' and 'Total Rows: 8'. Buttons for 'Clear Changes' and 'Apply' are located at the top right of this section.

Down Converter Frequencies: This section features a table with columns for Port Number and Frequency (MHz). The table lists ports 1 through 8, each with a frequency of 0 MHz. A 'Total Rows: 8' indicator is present at the bottom right of the table.

The Downconverter Frequencies section can be used to set a frequency translation that the Decimator will apply to the spectrum. The provided value will be added to the frequency of each trace point before it is provided to the user. This can be used to account for external frequency-translating equipment, such as downconverters, located between the input signal and the Decimator's input port, so that the signal is displayed at its original frequency. Note that the Decimator does not include any internal frequency translation related to this setting, as it is intended to only account for translation that occurs external to the Decimator hardware.

2.2.3.4 Port Names

The *Port Names* tab is used to modify the names of the ports.

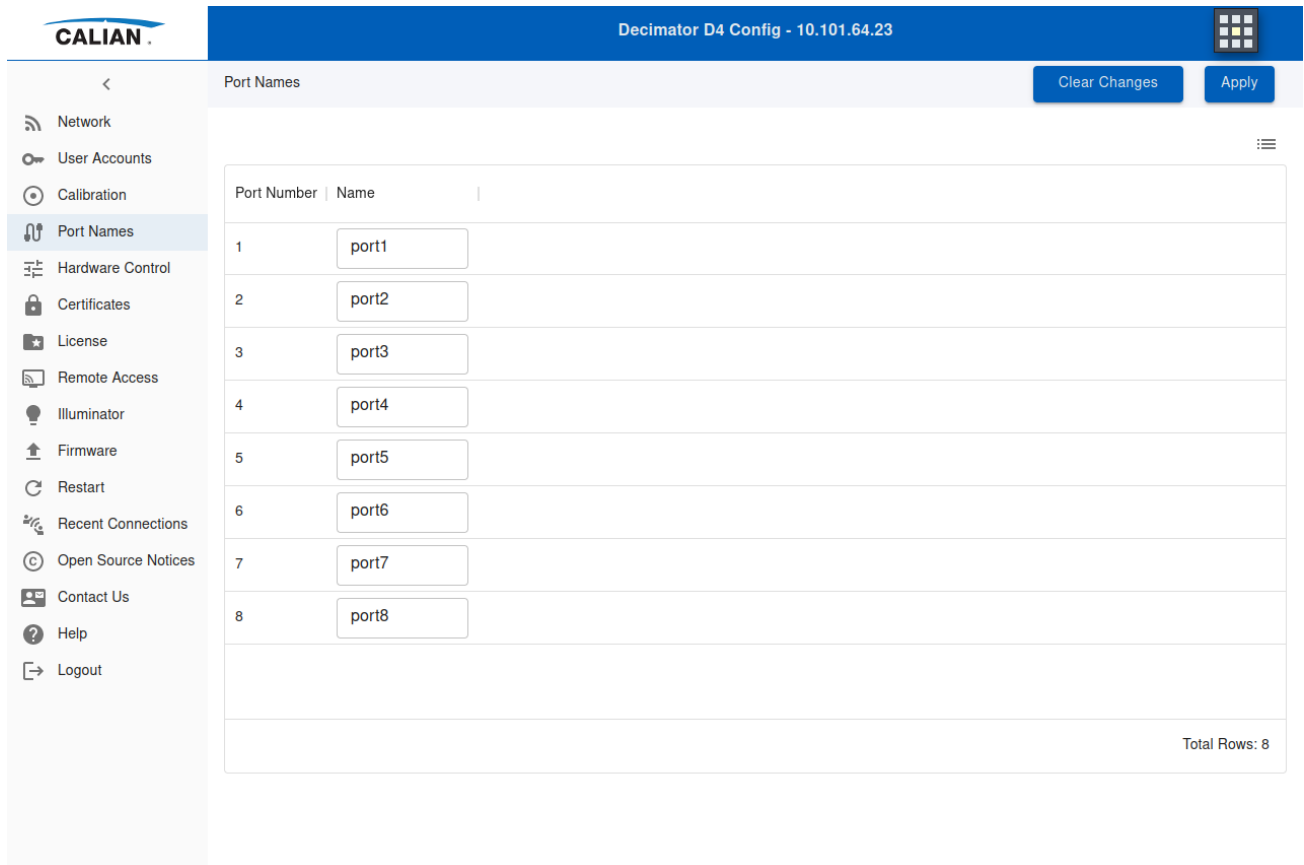

The screenshot shows the CALIAN Decimator D4 Config web interface. The top bar displays the CALIAN logo and the title "Decimator D4 Config - 10.101.64.23". The sidebar menu on the left includes options like Network, User Accounts, Calibration, Port Names (selected), Hardware Control, Certificates, License, Remote Access, Illuminator, Firmware, Restart, Recent Connections, Open Source Notices, Contact Us, Help, and Logout. The main content area is titled "Port Names" and features a table with 8 rows. Each row has a "Port Number" column and a "Name" column with a text input field. The names are currently set to "port1" through "port8". At the top right of the main area are "Clear Changes" and "Apply" buttons. At the bottom right, it says "Total Rows: 8".

Port Number	Name
1	port1
2	port2
3	port3
4	port4
5	port5
6	port6
7	port7
8	port8

On the GUI, these names will be displayed in the switch port drop down menu. For example, assume port 1 was named *Telesat*. The GUI would display *1 - Telesat*. This feature is a convenience for the user and has no effect on the measurements made on the hardware.

After the switch port names are modified, click the *Apply* button at the top right.

2.2.3.5 Certificates

The Certificates tab is used to add and customize digital certificates for encryption.

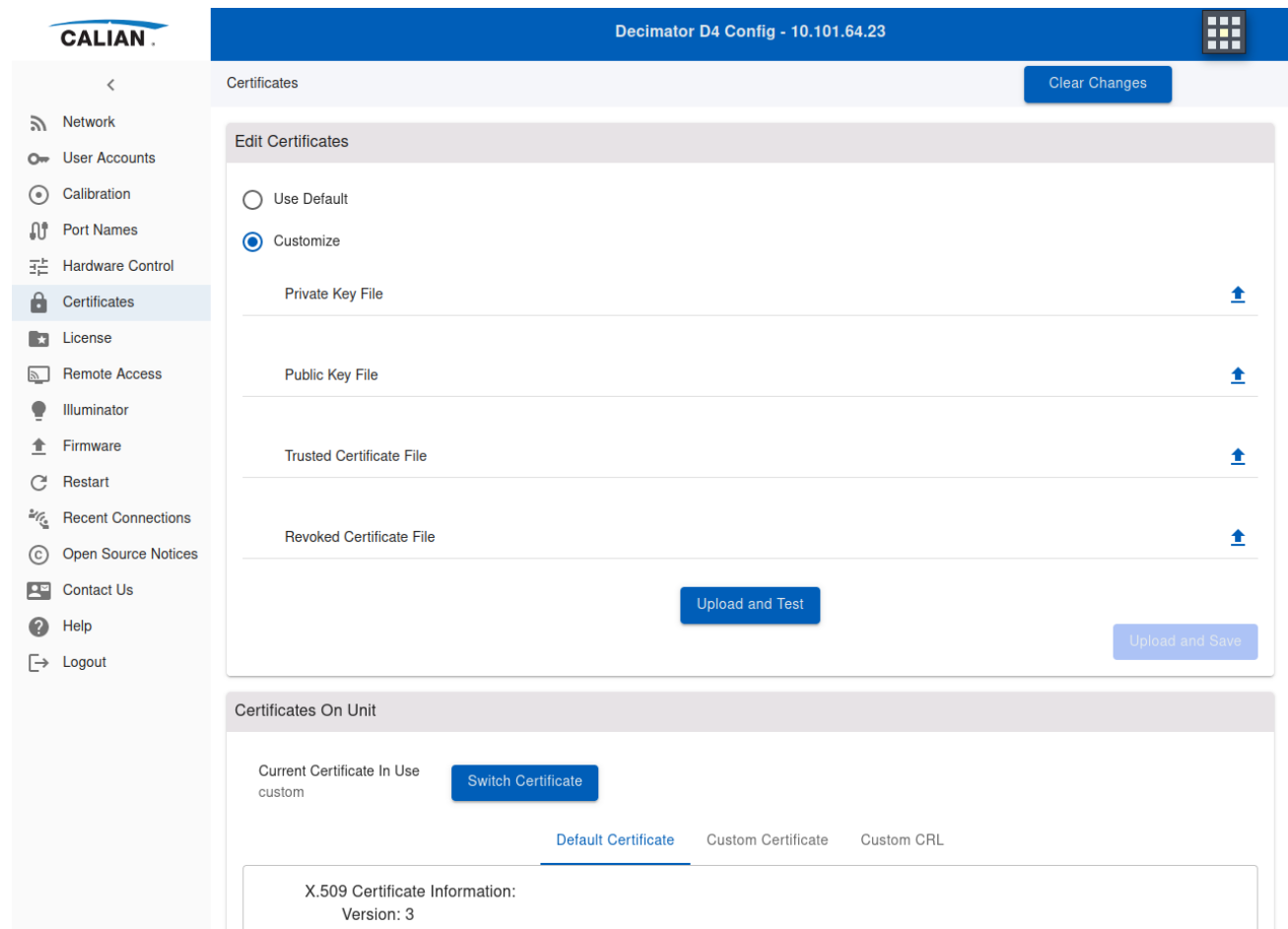

The web server front end, which allows communication between the browser and the D4 application, uses HTTPS to secure the traffic. The D4 product is shipped with encryption keys from the factory, but these keys may not meet the needs of all users, as they will trigger warnings in the browser when first connecting.

Users are able to replace the encryption keys on the web server with their own keys. They can also provide information about revoked certificates if needed.

Encryption keys in the web server are configured as a pair of files, usually in PEM format. The public key file is provided to the web browser on first connection; it identifies the authority (called the certificate authority) for identifying the D4 device. The public key file will consist of one or more certificate authority files concatenated together to form the chain of authority that the browser uses to verify the D4 device. The private key file is created by the certificate authority, the certificate provider.

The certificate revocation information is provided as a pair of files. The certificate authority file is used to authenticate the certificate revocation list (CRL) file contents. Maintaining the revocation list is the responsibility of the customer.

The D4 network security user interface allows uploading two or four files. The public and private key files are always required in the upload screen, while the CRL certificate authority and contents files are optional. The security upload screens provide two stages: the first stage allows the customer to upload 2 or 4 files to the server and have them verified. Once the files have been verified by the D4 web server, the customer will be able to upload the same files to the production area for operational use.

To upload new certificate files, under the *Edit Certificates* section, select the *Customize* radio button. Click the upload buttons next to each field and select the appropriate files to upload, then click the *Upload and Test* button. If the D4 successfully verifies the certificate files, the *Upload and Save* button will become enabled. Click *Upload and Save* to commit the changes and begin using the new certificate files.

The certificates may also be viewed or downloaded from the same page.

2.2.3.6 License

The *License* tab is used to modify the available features of the Decimator.

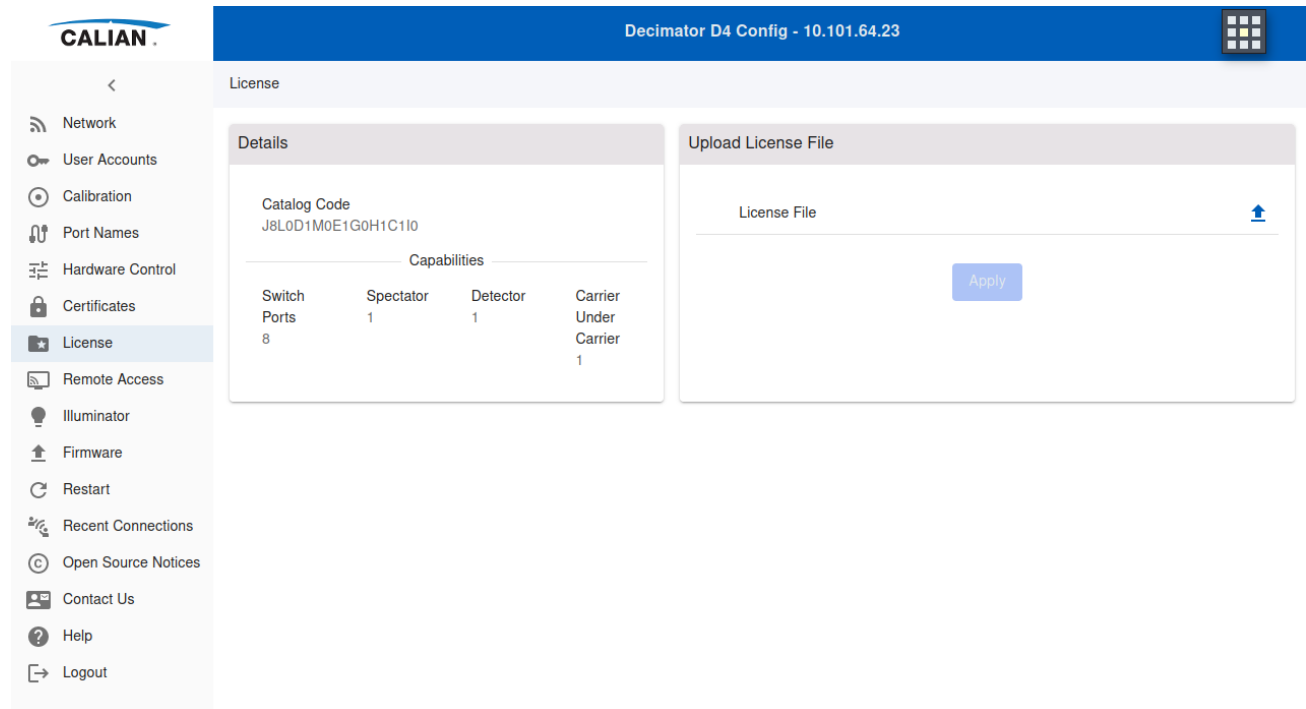

Capabilities			
Switch Ports	Spectator	Detector	Carrier Under Carrier
8	1	1	1

For example, the license file can be used provide access to:

- Four or eight ports for the Multiport Decimator
- Spectator feature
- Future product features

Note that the license files are NOT used to upgrade the firmware. See section 2.2.3.8 for updating the firmware on the Decimator.

To begin the license file upgrade, first click the *Choose file* button and select the license file provided by Calian. Then click the *Apply* button to transfer the file to the Decimator. The Decimator will verify the contents of the file and, if the file is successfully validated, apply the new license. Once the new license file has been applied, click the *Reboot* button for the new changes to take effect. If the Decimator fails to validate the file, it will continue to use the existing configuration.

2.2.3.7 Remote Access

The *Remote Access* tab allows you to enable or disable the network services on open Decimator ports, as well as set the port numbers. Closing unused ports enhances the security of the device.

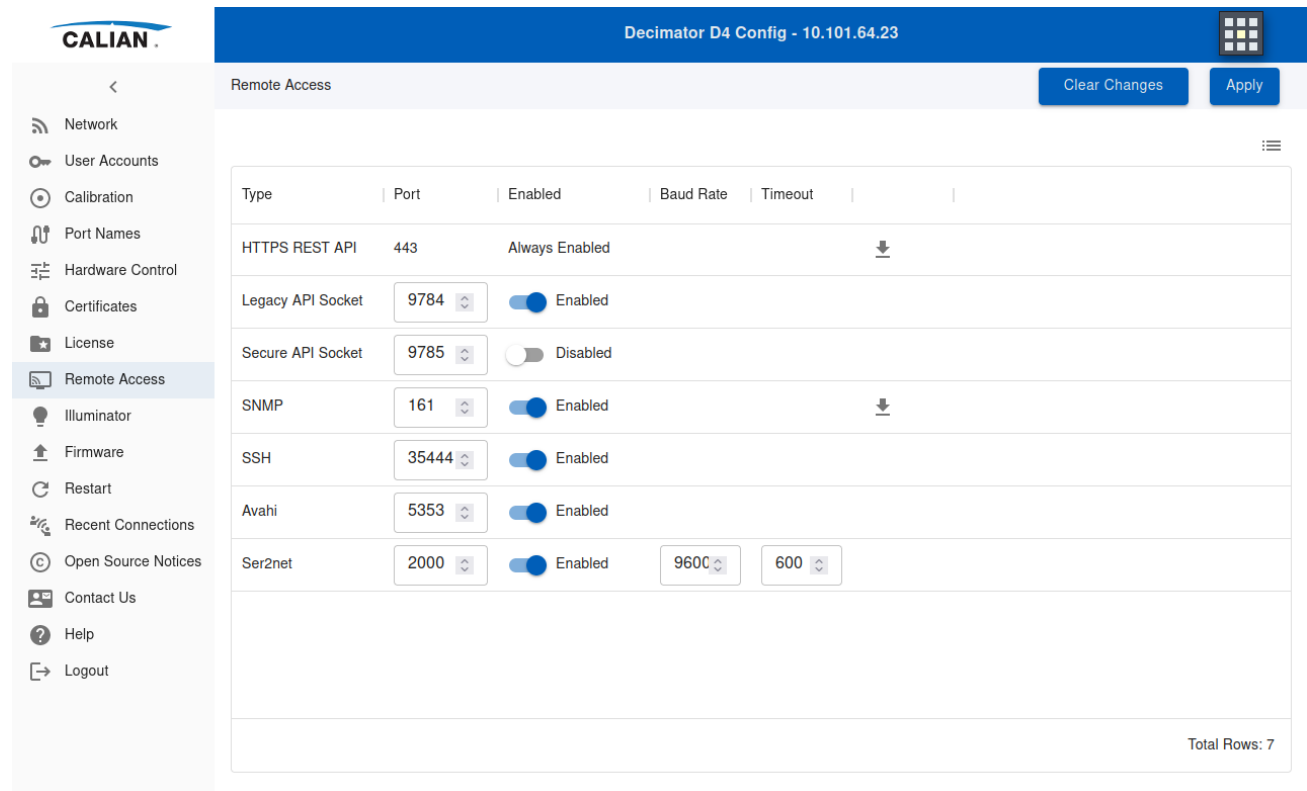

Type	Port	Enabled	Baud Rate	Timeout
HTTPS REST API	443	Always Enabled		↓
Legacy API Socket	9784	Enabled		
Secure API Socket	9785	Disabled		
SNMP	161	Enabled		↓
SSH	35444	Enabled		
Avahi	5353	Enabled		
Ser2net	2000	Enabled	9600	600

Total Rows: 7

The Decimator provides the following network services on the *Remote Access* page:

- *HTTPS REST API* provides GUI access to the Decimator along with low level programmatic control for developers who want to independently access the Decimator through a curl script for example. The port for this interface cannot be changed. The Swagger file for the REST API is downloadable by clicking on the “API Definition” button. To look at the programmatic control, see the next section.
- *Legacy API Socket* and *Secure API Socket* is provided for those with Decimator D3 units to maintain backwards compatibility. For new users, it is highly recommended to use the *HTTPS REST API* instead. These interfaces are used to configure and initiate measurements, retrieve measurement data, and monitor status.
- The *SNMP* interface provides information about the status of Decimator. SNMPv2 is supported. Parameters including voltage, temperatures, etc. can be monitored through SNMP. The SNMP interface cannot be used to perform measurements. The MIB is downloadable, by clicking on the “Download MIBs” button.
- An *SSH* interface is provided for development and debug purposes only.

- An Avahi interface is a service which allows discovery of a device on a local network by its hostname, via multicast DNS. The D4 will show up as <hostname>.local on the lookup.
- A Ser2net interface is a serial to network proxy that allows the user to control a serial port on the card via a TCP telnet session. The user connects to a TCP port on the Decimator, and the Decimator will forward any traffic to and from that port to a serial port on the device, allowing the user to remotely control a serial device connected to the Decimator hardware.

2.2.3.7.1 Programming the D4 Via the HTTPS REST API

The D4 server is accessed and controlled via a RESTful API web service. Since this is a stateless interface, all required information needed for acquiring traces and perform measurements, amongst other things, needs to be passed into the REST API call. The advantage is that the D4 unit will configure the hardware with exactly what is passed in, and perform the trace acquisition or measurement, providing the result back to the client user. Under the hood, the D4 services each of these client requests in roughly a round robin manner, one or more could be a separate D4 UI session. As more clients are added, the user experience of the clients using the D4 will slow down. Realistically, it is good to keep the number of clients down to 5 or less, but you could use 10 clients that are making quick measurements. Timeouts may start to occur if the hardware is under high usage due to a large number of clients, or capture configurations that take longer to complete, or a combination of both. Captures using wide spans, low RBWs, and/or large number of averages will take longer to complete.

2.2.3.7.1.1 Downloading and Viewing the Swagger File

Users can download the Swagger file, “swaggerDefinition.yml” file by clicking on the “API Definition” button on the Config / Remote Access tab. For easier viewing of the Swagger file use the online editor/viewer at “<https://editor.swagger.io>”. The Swagger file is broken down into 5 main sections:

- Decimator
 - The main Decimator APIs
 - Two of the most frequently used being
 - getTrace
 - performMeasurement
 - See the documentation in the swagger file for more details.
- ACE
 - This is used for automatic carrier extraction
- Config
 - This is used for the config pages in the UI

- Illuminator
 - This is used for the advanced multi-site carrier monitoring Illuminator product by Calian
- Demodulator
 - This is used for demodulation analysis

2.2.3.7.1.2 Getting Runtime Examples on How to Use a Specific REST API Endpoint

Before trying to create your command line API interface to the D4 using the Swagger file directly, it is good to get an example feel on how the D4 UI uses the REST API. To view this in action, drive the D4 UI into your specific use case after doing the following:

- open the D4 UI to your D4 in a Chrome browser
- execute the following keystroke <Ctrl><Shift><i> to bring up the developer tools, other browsers have something similar
- click on the Network tab in the developer tools
- below you will see a list of all the REST API's being called
- select one with your mouse
- on the right, you will be able to see the 4 most significant tabs of interest:
 - Headers
 - Shows the headers packed into the request. See the Authentication section below for more details
 - Payload
 - Shows the request payload going from the client to the D4 REST Service
 - Preview
 - Show the entire request as is
 - Response
 - Shows the response JSON data from the D4 REST Service going back to the client

Note you can use a right click on the values in the tabs of interest to copy the values to the clipboard for use later when creating curl scripts. Since many of the request parameters are long, this is a time saver.

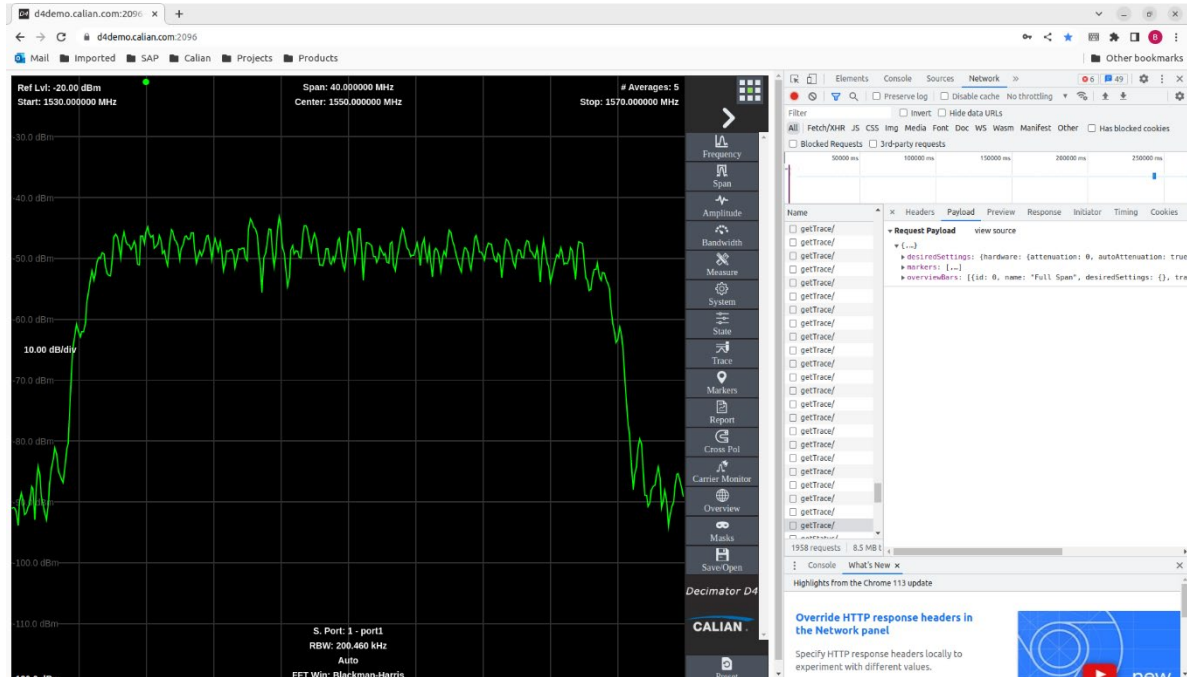

2.2.3.7.1.3 Authentication with the REST API Endpoint – A Little More Detail

The authentication scheme used by the D4 is in the header that validates credentials as follows:

- key: "authorization"
- value: "BasicSED <base64Encoding of username:password>"

for example, for a username = John and password = Smith the value would be "BasicSED Sm9objpTbWl0aA=="

- where John:Smith encoded in Base 64 is Sm9objpTbWl0aA==

To encode your username and password quickly:

- navigate to <https://www.base64encode.org/>
- enter John:Smith in the text area at the top
- click "Encode"
- the encoded username and password is in the bottom text area
- click "Copy to clipboard" button to copy this to the clipboard
- paste this into your curl script
- You will need to ensure a valid user and password is passed in the header of the request. Consult the User Accounts section 2.2.3.2 of the User Manual for more information.

2.2.3.7.1.4 Create Your Own Curl Script

Once you have this above information, you can create your own curl scripts using the data from the above Runtime Examples from the D4 UI, along with cross referencing this with the swagger file for more detail.

2.2.3.7.1.5 More Advanced Client Usages

Other tools can ingest a swagger file and generate client code directly in your development language of choice. From there, developers can use the generated code to access the D4 web server.

2.2.3.8 Firmware

The *Firmware* tab is used for managing firmware upgrades. This eliminates the need to return the Decimator to the factory for updates. Upgrading license files to increase the functionality of the Decimator (e.g., the number of switch ports, Spectator) is handled separately, as described in section 2.2.3.6.

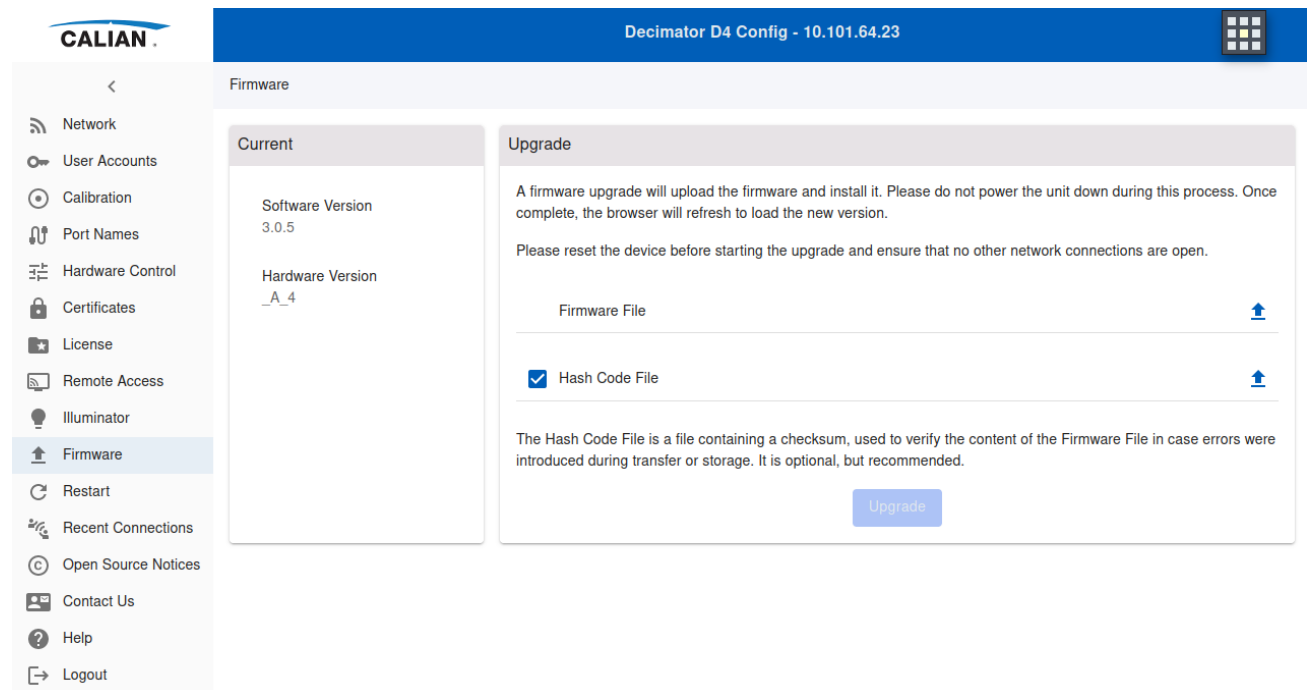

Restart the Decimator before installing firmware and ensure there are no API connections made, including the GUI, HTTPS REST API, and the legacy socket API, after the restart and during the installation. The Decimator can be restarted in the *Reset* tab or by toggling its power off and on.

The firmware update file supplied by Calian can be transferred to the Decimator through this tab. Select the firmware update file with the *Firmware File Choose file* button. If a hash code file is to be sent as well then select that as well, otherwise uncheck the *Verify Hash Code* check box. Click the *Upgrade* button to begin the upgrade. Including the hash code file is recommended.

A confirmation dialog will appear to verify the upgrade. Click Yes to begin the upgrade. Once the upgrade is complete, the Decimator will restart and the GUI will be refreshed. Any logged in users will receive a notification explaining why the GUI is being automatically refreshed.

2.2.3.9 Reset

The *Reset* tab is used to trigger a hardware reboot of the Decimator. Click the *Hardware Reset* button to cause a confirmation dialog to be displayed. Click *Yes* to trigger a reboot of the Decimator.

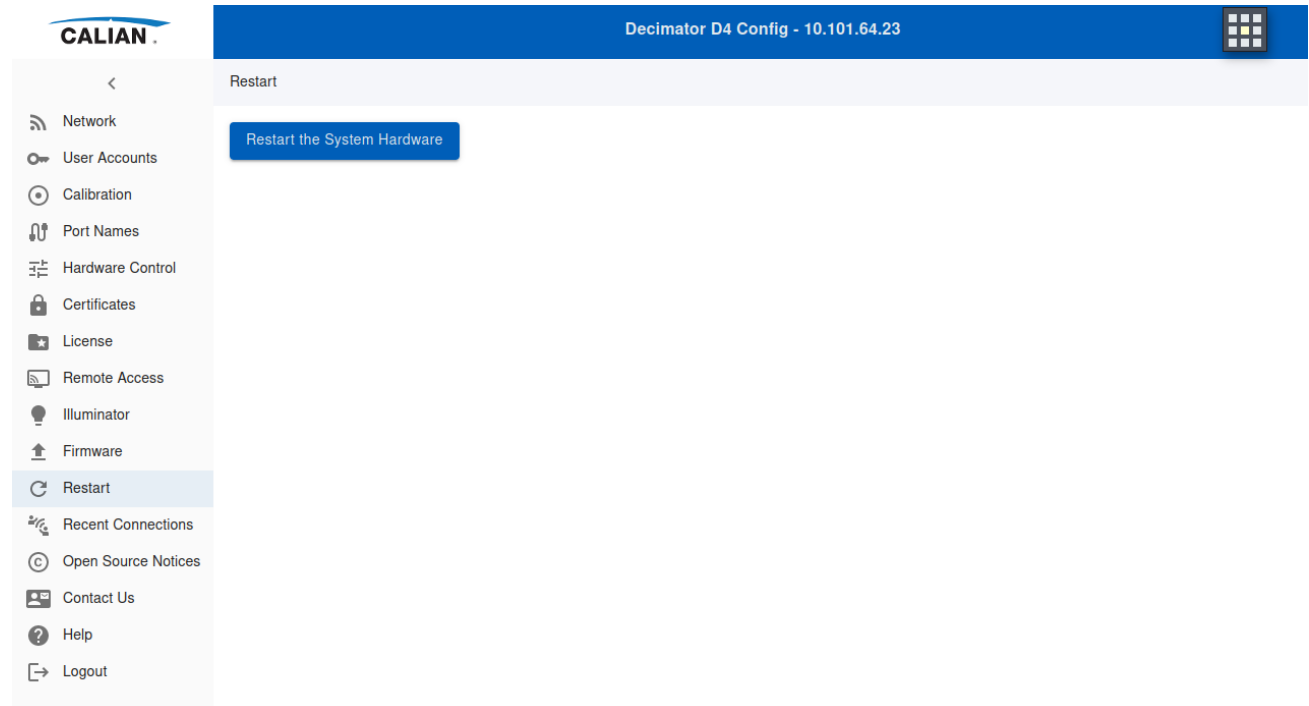

2.2.3.10 Recent Connections

The *Recent Connections* tab displays the user name, IP address, session name, and start time of all currently active user connections via the Decimator GUI and API interfaces.

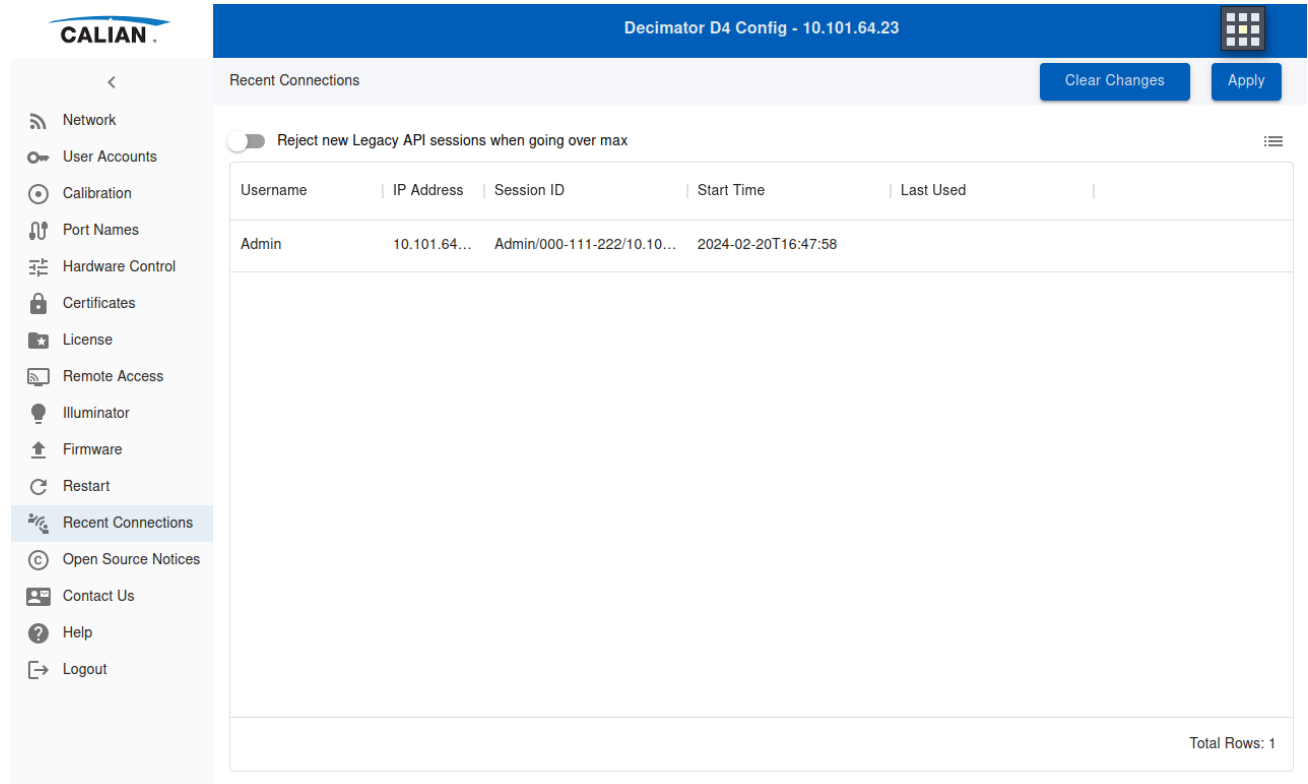

The screenshot shows the 'Recent Connections' tab in the Decimator D4 Config web interface. The interface has a blue header with the CALIAN logo and the title 'Decimator D4 Config - 10.101.64.23'. A left sidebar contains a navigation menu with items like Network, User Accounts, Calibration, Port Names, Hardware Control, Certificates, License, Remote Access, Illuminator, Firmware, Restart, Recent Connections (highlighted), Open Source Notices, Contact Us, Help, and Logout. The main content area shows a toggle switch for 'Reject new Legacy API sessions when going over max' and a table with columns: Username, IP Address, Session ID, Start Time, and Last Used. The table contains one row for 'Admin' with IP '10.101.64...' and Session ID 'Admin/000-111-222/10.10...'. The start time is '2024-02-20T16:47:58'. At the bottom right, it says 'Total Rows: 1'. There are 'Clear Changes' and 'Apply' buttons in the top right of the main area.

Username	IP Address	Session ID	Start Time	Last Used
Admin	10.101.64...	Admin/000-111-222/10.10...	2024-02-20T16:47:58	

2.2.3.11 Open Source Notices

The *Open Source Notices* tab displays information about the open source software used by the Decimator in the user interface and server software.

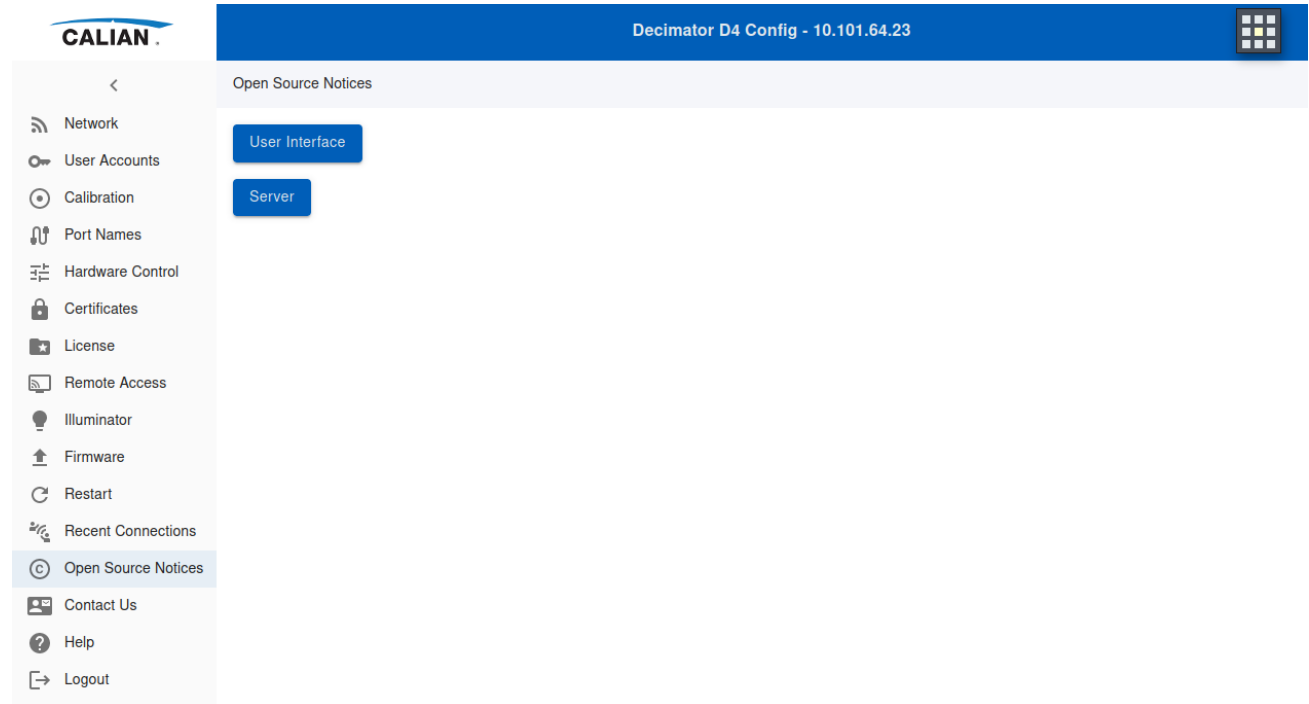

2.2.3.12 Contact Us

The *Contact Us* tab displays useful contact and product support information.

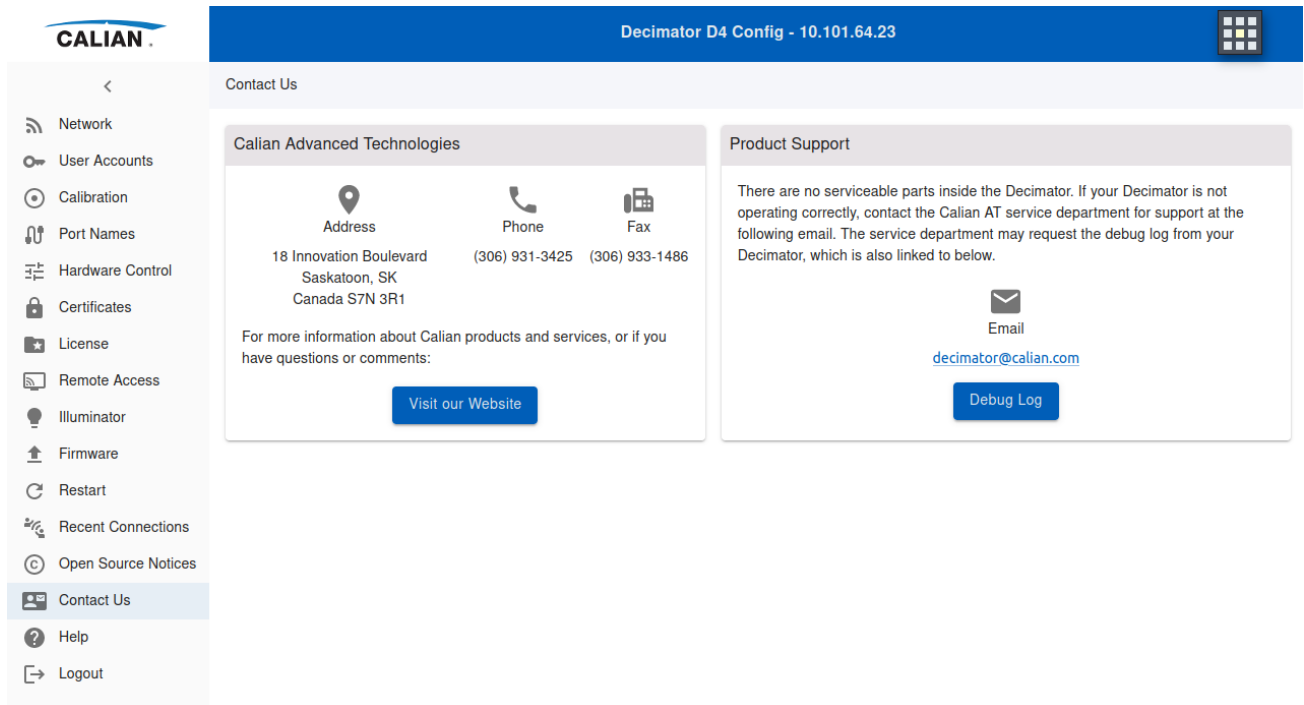

The screenshot shows the 'Contact Us' page in the Decimator D4 Config interface. The page is titled 'Decimator D4 Config - 10.101.64.23'. The left sidebar contains a navigation menu with the following items: Network, User Accounts, Calibration, Port Names, Hardware Control, Certificates, License, Remote Access, Illuminator, Firmware, Restart, Recent Connections, Open Source Notices, **Contact Us**, Help, and Logout. The main content area is divided into two sections: 'Calian Advanced Technologies' and 'Product Support'. The 'Calian Advanced Technologies' section displays the company's address (18 Innovation Boulevard, Saskatoon, SK, Canada S7N 3R1), phone number ((306) 931-3425), and fax number ((306) 933-1486). It also includes a 'Visit our Website' button and a prompt for more information. The 'Product Support' section contains a message stating that there are no serviceable parts inside the Decimator and provides an email address (decimator@calian.com) for support, along with a 'Debug Log' button.

2.2.3.13 Help

The *Help* tab allows you to access this user manual.

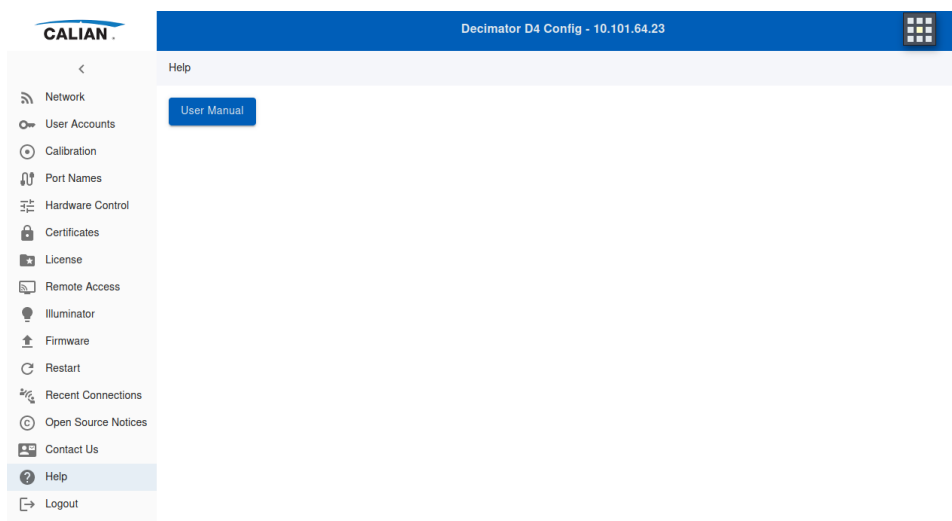

The screenshot shows the 'Help' page in the Decimator D4 Config interface. The page is titled 'Decimator D4 Config - 10.101.64.23'. The left sidebar contains a navigation menu with the following items: Network, User Accounts, Calibration, Port Names, Hardware Control, Certificates, License, Remote Access, Illuminator, Firmware, Restart, Recent Connections, Open Source Notices, Contact Us, **Help**, and Logout. The main content area displays a single 'User Manual' button.

2.2.4 Spectrum

The basic *Spectrum* operations collect the samples required for the selection made, perform a windowed FFT, and display the spectrum data. Similar to traditional spectrum analyzers, the speed of the measurement is a function of the RBW and the span.

2.2.4.1 Main Screen

The main screen allows you to view and control the spectrum plot.

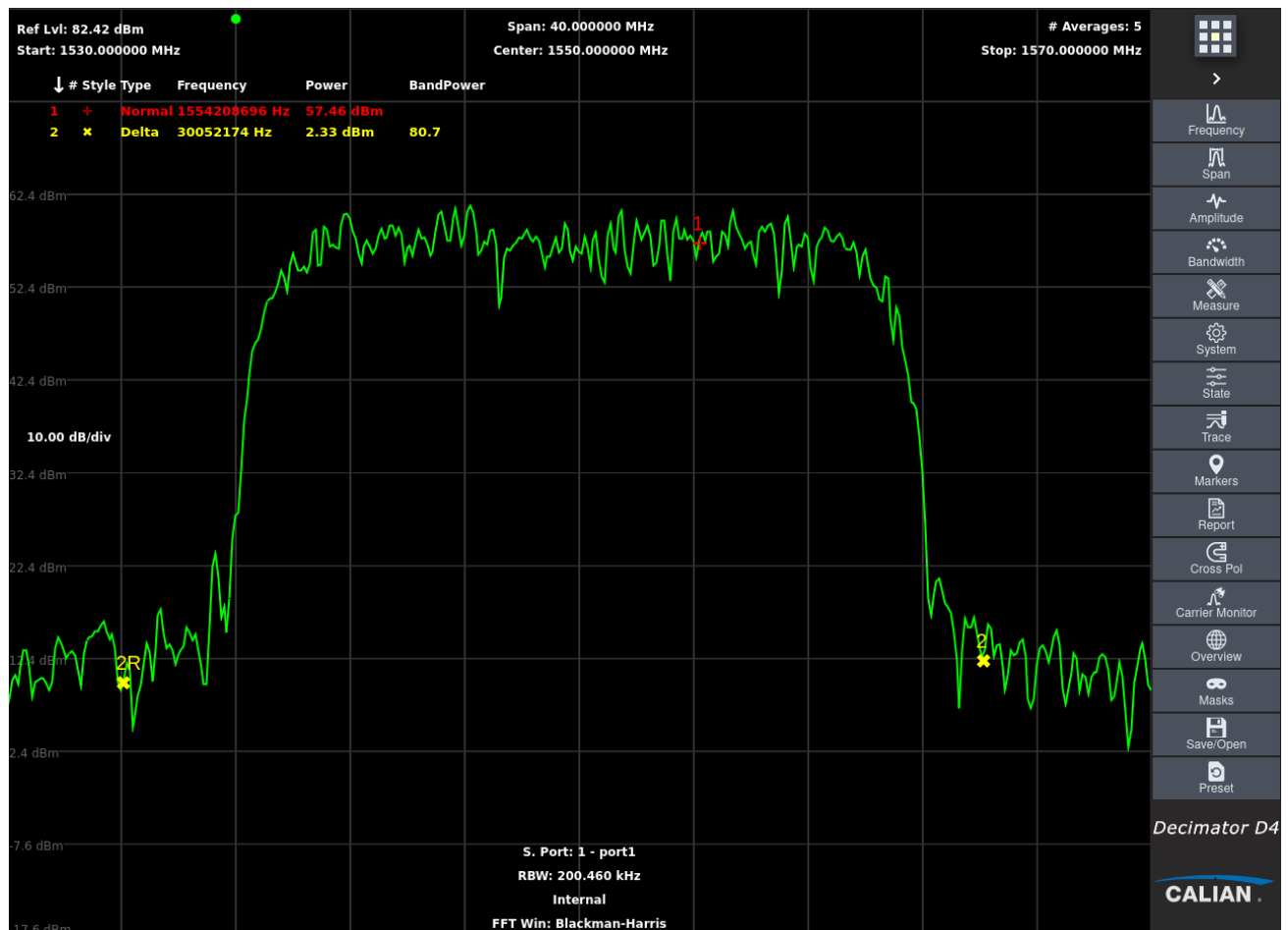

The main screen automatically updates the values of the various parameters in real time as the signal changes or as you change parameters. Click one of the white labels (e.g. *Center: 1550.000000 MHz*) on the main screen to open the edit dialog for that setting.

The main screen consists of these areas:

- Plot area in the center displays the grid and plot of the signal.
- Marker table near the top left. When a marker is turned on, a marker table displays the marker values over the plot area. This table can be dragged to different positions in the plot area. It can also be collapsed and expanded by clicking on a cell in the header row.
- Top settings bar displays the connection LED, reference level, span, number of averages, start frequency, center frequency, and stop frequency. These labels also provide a short cut link to their respective editors by clicking on them.
- Left settings bar displays the scale per division and minimum displayed power level. These labels also provide a short cut link to their respective editors by clicking on them.
- Bottom settings bar displays the resolution bandwidth, reference source, and FFT window in the center. These labels also provide a short cut link to their respective editors by clicking on them.
- Mouse coordinates are displayed in the bottom right corner in frequency and power.

2.2.4.2 Spectrum Menu

The *Spectrum* menu resides along the right side of the GUI. Click on one of these buttons to highlight it blue and reveal another column of buttons to the left. These buttons will have related submenu functions to change values or open another menu.



2.2.4.2.1 Buttons

There are two types of buttons used by the Decimator: navigation and value buttons.

- There are two types of navigation buttons:
 - A button containing an image and the title of the submenu it opens. It can also be collapsed to display only the image, where you can hover the mouse over the button to see a tool tip that contains the title of the menu.



- A button containing only the title of the submenu it opens. Click the button to replace the menu that was currently open with the submenu. A back button appears in the menu's title to allow you to return to the previous menu.



- Value buttons open a dialog that allows input, a selection, or toggling of a value. The button contains a title with a value underneath, although some value buttons only have a title.



2.2.4.2.2 Editors

There are various editors associated with the value buttons.

2.2.4.2.2.1 Frequency Input

A frequency input dialog is used to enter a frequency value.

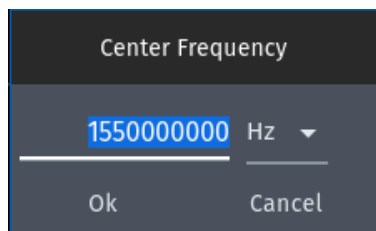

These dialogs consist of a text field and a selection field. Every frequency input requires a positive floating-point value. Entering a negative number, leaving it blank, or entering a string will cause an error message to appear and clicking *Ok* will not submit the changes. Some frequency inputs validate the entered number is within a defined range, and an error message will be displayed if a value exceeds a defined minimum or maximum value. The selection field allows you to choose the units for the value as Hz, kHz, MHz, and GHz.

2.2.4.2.2.2 Text/Numerical Input

A text/numerical input dialog is used to enter a value where the unit of measurement is predetermined.

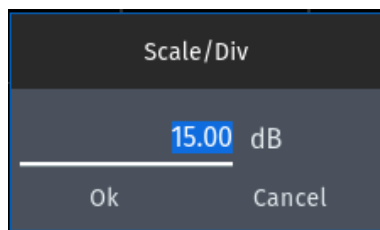

These dialogs have a text entry field with the predetermined unit displayed beside the field. Where there is no unit, the entry field will stretch across the dialog. You will be informed when an invalid range, number, or string is entered and the *Ok* button will not submit the data until you have corrected it.

2.2.4.2.2.3 Color Input

A Color Input dialog is used to select a color for various objects.



The dialog allows you to choose colors by entering the Hex or RGB value, or by clicking and dragging.

2.2.4.2.2.4 Selection

Selection buttons are used to choose from a list of options. For example, changing the thickness of a line where the current value is 1.



The dialog highlights the current value used by the Decimator. Click on any of the listed options to submit the change.

2.2.4.2.2.5 Toggle

Toggle buttons are used to flip between two settings.

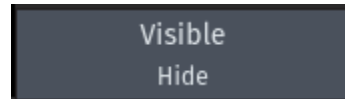

Click the button to change the current setting to the other option.

2.2.4.2.3 Menu Summary

The following table describes each button and data field of the *Spectrum* menu.

Button	Menu Item	Description								
<i>Frequency</i>	<i>Center Frequency</i>	Display the center frequency value. Click this menu item to display the center frequency edit dialog. Setting a value too low or too high is automatically adjusted to the actual value of the Decimator's limits.								
	<i>Start Frequency</i>	Display the start frequency value. Click this menu item to display the start frequency edit dialog. Setting a value too low or too high is automatically adjusted to the actual value of the Decimator's limits.								
	<i>Stop Frequency</i>	Display the stop frequency values. Click this menu item to display the stop frequency edit dialog. Setting a value too low or too high is automatically adjusted to the actual value of the Decimator's limits.								
	<i>Line1 Frequency</i>	<p>A vertical frequency line is drawn at the specified frequency value. The line is draggable with the mouse. Click this menu item to set it visible and initialize the frequency to $\frac{1}{4}$ span if the frequency line is not within the span.</p> <table border="1" style="width: 100%;"> <tbody> <tr> <td><i>Visible</i></td> <td>Whether or not the frequency line is visible. <ul style="list-style-type: none"> • <i>Show</i> • <i>Hide</i> </td> </tr> <tr> <td><i>Frequency</i></td> <td>Display the frequency edit dialog to allow setting of the frequency.</td> </tr> <tr> <td><i>Color</i></td> <td>The color of the frequency line. Displays a color edit dialog.</td> </tr> <tr> <td><i>Thickness</i></td> <td>The thickness of the frequency line in pixels. <ul style="list-style-type: none"> • 1 (default) • 2 to 5 </td> </tr> </tbody> </table>	<i>Visible</i>	Whether or not the frequency line is visible. <ul style="list-style-type: none"> • <i>Show</i> • <i>Hide</i> 	<i>Frequency</i>	Display the frequency edit dialog to allow setting of the frequency.	<i>Color</i>	The color of the frequency line. Displays a color edit dialog.	<i>Thickness</i>	The thickness of the frequency line in pixels. <ul style="list-style-type: none"> • 1 (default) • 2 to 5
<i>Visible</i>	Whether or not the frequency line is visible. <ul style="list-style-type: none"> • <i>Show</i> • <i>Hide</i> 									
<i>Frequency</i>	Display the frequency edit dialog to allow setting of the frequency.									
<i>Color</i>	The color of the frequency line. Displays a color edit dialog.									
<i>Thickness</i>	The thickness of the frequency line in pixels. <ul style="list-style-type: none"> • 1 (default) • 2 to 5 									
	<i>Line 2 Frequency</i>	A vertical frequency line is drawn at the specified frequency value. The line is draggable with the mouse. Click this menu item to set it visible and initialize the frequency to $\frac{3}{4}$ span if the frequency line is not within the span. This provides the same menus and user entries as <i>Line 1 Frequency</i> above.								

Button	Menu Item	Description								
Span	<i>Span</i>	Display the span value. Click this menu item to display the span frequency edit dialog. Setting a value too low or too high is automatically adjusted to the actual value of the Decimator's limits.								
	<i>Full Span</i>	Set the span to 6730 MHz and the center frequency to 3365 MHz. The Decimator is in wide sweep mode.								
	<i>Min Span</i>	Set the span to 100 Hz.								
	<i>Quick Span</i>	Set the span to one of the specified quick values in the combo box. <ul style="list-style-type: none"> • 1 MHz • 10 MHz • 50 MHz • 100 MHz • 500 MHz • 1 GHz 								
Amplitude	<i>Auto Y-axis</i>	Whether or not the Decimator will set the <i>Reference Level</i> and <i>Scale/Div</i> to an appropriate value to show the entire active trace in view. <ul style="list-style-type: none"> • <i>True</i> • <i>False</i> 								
	<i>Reference Level</i>	The reference or power level at the top of the screen in dBm. This value will be automatically set if <i>Auto Y-axis</i> is set to true.								
	<i>Scale/Div</i>	The scale per vertical division in dB. This value will be automatically set if <i>Auto Y-axis</i> is set to true.								
	<i>Auto Atten.</i>	The attenuation level is automatically set to the appropriate value, depending on the power level of the incoming signal. <ul style="list-style-type: none"> • <i>True</i>: Disables <i>Manual Atten.</i> menu • <i>False</i>: Enables <i>Manual Atten.</i> menu 								
	<i>Manual Atten.</i>	Stepped increments to adjust the input attenuation manually.								
	<i>Line 1 Ref</i>	A horizontal reference line is drawn at the specified power value. The line is draggable with the mouse. Click this menu item to set it visible and initialize the power to ¼ down from the reference value if the power line is not within the vertical viewport. <table border="1" style="width: 100%; margin-top: 10px;"> <tr> <td><i>Visible</i></td> <td>Whether or not the reference line is visible. <ul style="list-style-type: none"> • <i>Show</i> • <i>Hide</i> </td> </tr> <tr> <td><i>Power</i></td> <td>Display the power edit dialog to allow setting of the power.</td> </tr> <tr> <td><i>Color</i></td> <td>The color of the power line. Displays a color edit dialog.</td> </tr> <tr> <td><i>Thickness</i></td> <td>The thickness of the power line in pixels. <ul style="list-style-type: none"> • 1 (default) • 2 to 5 </td> </tr> </table>	<i>Visible</i>	Whether or not the reference line is visible. <ul style="list-style-type: none"> • <i>Show</i> • <i>Hide</i> 	<i>Power</i>	Display the power edit dialog to allow setting of the power.	<i>Color</i>	The color of the power line. Displays a color edit dialog.	<i>Thickness</i>	The thickness of the power line in pixels. <ul style="list-style-type: none"> • 1 (default) • 2 to 5
<i>Visible</i>	Whether or not the reference line is visible. <ul style="list-style-type: none"> • <i>Show</i> • <i>Hide</i> 									
<i>Power</i>	Display the power edit dialog to allow setting of the power.									
<i>Color</i>	The color of the power line. Displays a color edit dialog.									
<i>Thickness</i>	The thickness of the power line in pixels. <ul style="list-style-type: none"> • 1 (default) • 2 to 5 									

Button	Menu Item	Description						
	<i>Line 2 Ref</i>	A horizontal reference line is drawn at the specified power value. The line is draggable with the mouse. Click this menu item to set it visible and initialize the power to $\frac{3}{4}$ down from the reference value if the power line is not within the vertical viewport. This provides the same menus and user entries as <i>Line 1 Ref</i> above.						
	<i>Max Ref Line</i>	<p>A horizontal reference line is drawn at the maximum power value of the trace along with a label of the power value. Click this menu item to set it visible.</p> <table border="1" style="width: 100%; border-collapse: collapse;"> <tr> <td style="width: 25%;"><i>Visible</i></td> <td>Whether or not the reference line is visible. <ul style="list-style-type: none"> • <i>Show</i> • <i>Hide</i> </td> </tr> <tr> <td><i>Color</i></td> <td>The color of the reference line. Displays a color edit dialog.</td> </tr> <tr> <td><i>Thickness</i></td> <td>The thickness of the reference line in pixels. <ul style="list-style-type: none"> • 1 (default) • 2 to 5 </td> </tr> </table>	<i>Visible</i>	Whether or not the reference line is visible. <ul style="list-style-type: none"> • <i>Show</i> • <i>Hide</i> 	<i>Color</i>	The color of the reference line. Displays a color edit dialog.	<i>Thickness</i>	The thickness of the reference line in pixels. <ul style="list-style-type: none"> • 1 (default) • 2 to 5
<i>Visible</i>	Whether or not the reference line is visible. <ul style="list-style-type: none"> • <i>Show</i> • <i>Hide</i> 							
<i>Color</i>	The color of the reference line. Displays a color edit dialog.							
<i>Thickness</i>	The thickness of the reference line in pixels. <ul style="list-style-type: none"> • 1 (default) • 2 to 5 							
	<i>Min Ref Line</i>	A horizontal reference line is drawn at the minimum power value of the trace along with a label of the power value. Click this menu item to set it visible. This provides the same menus and user entries as <i>Max Ref Line</i> above.						
Bandwidth	<i>RBW</i>	The resolution bandwidth or spacing between the points. Click this menu item to display a combo box with a list of the appropriate RBWs given the current span and FFT window. Range is 1 Hz to 15 MHz.						
	<i>RBW Mode</i>	The mode used. <ul style="list-style-type: none"> • <i>Auto</i> (default): Sets the RBW = span/ratio • <i>Manual</i>: Ratio is disabled; you have full control to independently specify an RBW 						
	<i>Ratio</i>	The ratio of the span to the RBW. Only used in <i>Auto RBW Mode</i> .						
	<i>VBW Mode</i>	The video bandwidth mode used. <ul style="list-style-type: none"> • <i>Average</i> (default): Use number of averages when capturing a trace, enables <i>Average</i> menu item, disables <i>VBW</i> menu item • <i>VBW</i>: Use VBW when capturing a trace. Enables <i>VBW</i> menu item, disables <i>Average</i> menu item 						
	<i>Average</i>	The number of averages. Click this menu item to display the number of averages edit dialog. Range is 1 to 255.						
	<i>VBW</i>	The video bandwidth used when capturing a trace.						

Button	Menu Item	Description
Measure	<i>Capture Mode</i>	The measurement capture mode. <ul style="list-style-type: none"> • <i>Continuous</i> • <i>Single</i> • <i>Stopped</i>
	<i>Restart</i>	Restart the measurement if in <i>Continuous Capture Mode</i> . This is useful if <i>Max Hold</i> , <i>Min Hold</i> , or <i>Min Max Active</i> mode is on while in <i>Continuous</i> mode as it resets the min and max hold traces.
	<i>FFT Window</i>	The Fast Fourier Transform window type. See also section 2.2.4.2.4. <ul style="list-style-type: none"> • <i>Rectangular</i> • <i>Flattop</i> • <i>Blackman-Harris</i> (default) • <i>Hamming</i> • <i>Hanning</i>
	<i>Spectral Inversion</i>	The spectral inversion setting. <ul style="list-style-type: none"> • <i>Off</i> • <i>On</i>
	<i>Optimization</i>	The optimization setting. See also section 2.2.4.2.4. <ul style="list-style-type: none"> • <i>Spurious</i> • <i>Speed</i>
	<i>Detector Type</i>	The type of detector used. <ul style="list-style-type: none"> • <i>Normal</i> • <i>Peak</i>
	<i>Hold</i>	The hold mode. <ul style="list-style-type: none"> • <i>Normal</i> (none) • <i>Max Hold</i> • <i>Min Hold</i> • <i>Min Max Active</i>

Button	Menu Item	Description
System	<i>Reference Select</i>	The reference source selection. <ul style="list-style-type: none"> • <i>External</i> • <i>Internal</i> • <i>Auto</i>
	<i>Switch Port</i>	On a Single Port Decimator, the switch port value will be set to 0 and disabled. On a Multiport Decimator, the values will be from 1 to 4 or 8.
	<i>Color Scheme</i>	The color scheme of the background and grid lines. <ul style="list-style-type: none"> • <i>Normal</i>: Black and blue • <i>Print</i>: White and blue
	<i>Connection Timeout</i>	The number of seconds to wait for a response from the Decimator. Default is 30 seconds and the range is 1 to 120 seconds. Setting the value to 1 second will detect network failures quicker. Setting the timeout to higher values will provide more time when running the GUI over a WAN with multiple GUIs connected.
	<i>Session Name</i>	The session name appears on the following: <ul style="list-style-type: none"> • Apps button dialog • Log in screens
	<i>Reset</i>	Perform a software reset of the Decimator.
	<i>Status</i>	Display the status of the Decimator in a display dialog.
	<i>Error Log</i>	Display a list of errors received by the Decimator GUI.
	<i>Help</i>	Display the Decimator GUI help.
State	<i>State 1 to State 10</i>	Store or restore the state of Decimator from storage of one state. When the state is captured, a paperclip icon is displayed on the menu item. <ul style="list-style-type: none"> • <i>Clear</i>: Clears the state • <i>Capture</i>: Stores the current state • <i>Recall</i>: Applies the stored state to the current state • <i>View</i>: View the stored state in a display dialog • <i>Name</i>: Name the state; the name will appear on the menu item

Button	Menu Item	Description										
<i>Trace</i>	<i>Active</i>	The trace color is displayed in the menu item. This trace also acts as the CrossPol trace when in CrossPol mode.										
		<table border="1" style="width: 100%;"> <tr> <td style="width: 25%;"><i>Visible</i></td> <td>Whether or not the active trace is visible. <ul style="list-style-type: none"> • <i>Show</i> • <i>Hide</i> </td> </tr> <tr> <td><i>Color</i></td> <td>The color of the active trace. Displays a color edit dialog.</td> </tr> <tr> <td><i>Thickness</i></td> <td>The thickness of the active trace in pixels. <ul style="list-style-type: none"> • 1 • 2 (default) • 3 to 5 </td> </tr> <tr> <td><i>Export to CSV</i></td> <td>Export the trace points to a CSV file. Displays a file save dialog.</td> </tr> </table>	<i>Visible</i>	Whether or not the active trace is visible. <ul style="list-style-type: none"> • <i>Show</i> • <i>Hide</i> 	<i>Color</i>	The color of the active trace. Displays a color edit dialog.	<i>Thickness</i>	The thickness of the active trace in pixels. <ul style="list-style-type: none"> • 1 • 2 (default) • 3 to 5 	<i>Export to CSV</i>	Export the trace points to a CSV file. Displays a file save dialog.		
		<i>Visible</i>	Whether or not the active trace is visible. <ul style="list-style-type: none"> • <i>Show</i> • <i>Hide</i> 									
		<i>Color</i>	The color of the active trace. Displays a color edit dialog.									
		<i>Thickness</i>	The thickness of the active trace in pixels. <ul style="list-style-type: none"> • 1 • 2 (default) • 3 to 5 									
<i>Export to CSV</i>	Export the trace points to a CSV file. Displays a file save dialog.											
	<i>CrossPol</i>	The trace color is displayed in the menu item. This trace is the cross-polarity trace when in CrossPol mode. This provides the same menus and user entries as <i>Active</i> above.										
	<i>Trace 1 to Trace 4</i>	Memory based traces.										
		<table border="1" style="width: 100%;"> <tr> <td style="width: 25%;"><i>Capture</i></td> <td>Copy the active trace to the stored trace. Displays a graph icon on the menu item and on the trace menu item one level above when captured.</td> </tr> <tr> <td><i>Clear</i></td> <td>Clear the trace from memory.</td> </tr> <tr> <td><i>Visible</i></td> <td>Whether or not the trace is visible. <ul style="list-style-type: none"> • <i>Show</i> • <i>Hide</i> </td> </tr> <tr> <td><i>Color</i></td> <td>The color of the stored trace. Displays a color edit dialog.</td> </tr> <tr> <td><i>Thickness</i></td> <td>The thickness of the memory trace in pixels. <ul style="list-style-type: none"> • 1 • 2 (default) • 3 to 5 </td> </tr> </table>	<i>Capture</i>	Copy the active trace to the stored trace. Displays a graph icon on the menu item and on the trace menu item one level above when captured.	<i>Clear</i>	Clear the trace from memory.	<i>Visible</i>	Whether or not the trace is visible. <ul style="list-style-type: none"> • <i>Show</i> • <i>Hide</i> 	<i>Color</i>	The color of the stored trace. Displays a color edit dialog.	<i>Thickness</i>	The thickness of the memory trace in pixels. <ul style="list-style-type: none"> • 1 • 2 (default) • 3 to 5
		<i>Capture</i>	Copy the active trace to the stored trace. Displays a graph icon on the menu item and on the trace menu item one level above when captured.									
		<i>Clear</i>	Clear the trace from memory.									
		<i>Visible</i>	Whether or not the trace is visible. <ul style="list-style-type: none"> • <i>Show</i> • <i>Hide</i> 									
		<i>Color</i>	The color of the stored trace. Displays a color edit dialog.									
<i>Thickness</i>	The thickness of the memory trace in pixels. <ul style="list-style-type: none"> • 1 • 2 (default) • 3 to 5 											

Button	Menu Item	Description	
		<i>Freq. Rendering</i>	<p>The frequency rendering mode.</p> <ul style="list-style-type: none"> • <i>Overlay</i>: Display the trace exactly as was taken, disregarding the frequency – this is a WYSIWYG of the trace when it was captured • <i>Absolute</i>: Display the trace in the exact frequency location – it may be off screen • <i>Shifted</i>: Display the trace centered in the center of the screen, but scale it in the frequency direction according to the new span
		<i>Ampl. Rendering</i>	<p>The amplitude rendering mode.</p> <ul style="list-style-type: none"> • <i>To Scale</i>: Display the trace in the vertical direction to scale • <i>Overlay</i>: Display the trace in the vertical direction as was taken during capture, disregarding the reference level
		<i>Export to CSV</i>	Export the trace points to a CSV file. Displays a file save dialog.
		<i>Details</i>	Display the settings at the time the trace was captured.
Markers	<i>Marker 1 to Marker 10</i>	<p>Markers that can be applied to traces. The markers are added to the active trace and then can be moved to memory-based traces. The trace color is displayed in the menu item. Note that markers can only be dragged using the mouse on memory-based traces that have <i>Freq. Rendering</i> set to <i>Absolute</i>.</p>	
		<i>Style</i>	<p>Set the style of the marker. When <i>Normal</i> or <i>Delta</i>, a paperclip graphic is shown.</p> <ul style="list-style-type: none"> • <i>Off</i>: Turns off the marker • <i>Normal</i>: A single marker • <i>Delta</i>: A pair of markers • <i>CrossPol</i>: A pair of markers on the <i>Active</i> and <i>CrossPol</i> traces when in <i>CrossPol</i> mode.

Button	Menu Item	Description	
		<i>Shape</i>	<p>The shape of the marker.</p> <ul style="list-style-type: none"> • <i>Plus</i> • <i>X</i> • <i>Diamond</i> • <i>Up Facing Triangle</i> • <i>Down Facing Triangle</i> • <i>Right Facing Triangle</i> • <i>Left Facing Triangle</i> • <i>Circle</i> • <i>Do Not Enter</i> • <i>Circle Plus</i>
		<i>Color</i>	The color of the marker. Displays a color edit dialog.
		<i>Trace</i>	<p>Show what trace the marker is attached to.</p> <ul style="list-style-type: none"> • <i>Active</i> • <i>CrossPol</i> • <i>1 to 4</i>
		<i>Frequency</i>	Enabled when the <i>Style</i> is <i>Normal</i> , <i>Delta</i> , or <i>CrossPol</i> , this displays the frequency edit dialog to adjust the marker frequency.
		<i>Function</i>	<p>Enabled when the <i>Style</i> is <i>Normal</i> or <i>Delta</i>, this displays the marker frequency functions.</p> <ul style="list-style-type: none"> • <i>Peak Search</i> • <i>Marker to Center Frequency</i> • <i>Marker to Reference Level</i> • <i>Next Peak Right</i> • <i>Next Peak Left</i> • <i>Next Lower Peak</i>
		<i>Freq. Adjust</i>	Enabled when the <i>Style</i> is <i>Normal</i> , <i>Delta</i> , or <i>CrossPol</i> , this displays a previous and next button, which move the marker one point left or right.
		<i>Reference Frequency</i>	Enabled when the <i>Style</i> is <i>Delta</i> or <i>CrossPol</i> , this displays the frequency edit dialog to adjust the reference frequency marker.

Button	Menu Item	Description	
		<i>Reference Function</i>	<p>Enabled when the <i>Style</i> is <i>Delta</i> or <i>CrossPol</i>, this displays the functions that can be performed on the reference frequency marker.</p> <ul style="list-style-type: none"> • <i>Peak Search</i> • <i>Marker to Center Frequency</i> • <i>Marker to Reference Level</i> • <i>Next Peak Right</i> • <i>Next Peak Left</i> • <i>Next Lower Peak</i>
		<i>Ref. Freq. Adjust</i>	<p>Enabled when the <i>Style</i> is <i>Delta</i> or <i>CrossPol</i>, this displays a previous and next button, which move the reference frequency marker one point left or right.</p>
Report	<i>Export to CSV</i>	<p>Export the data points of the active trace and any captured memory based traces to a CSV file. Displays a file name dialog. Saved files will go to the <i>Downloads</i> folder unless you have configured your browser to save downloads elsewhere.</p>	
	<i>Export to HTML</i>	<p>Export the screen, traces, markers, and states to an HTML file report. Displays a file name dialog. Saved files will go to the <i>Downloads</i> folder unless you have configured your browser to save downloads elsewhere.</p>	
CrossPol	<i>CrossPol Mode</i>	<p>The cross-polarity mode. Span must be less than 52 MHz. You should ensure proper values are set for the <i>Switch Port</i> and <i>CrossPol Switch Port</i> settings.</p> <ul style="list-style-type: none"> • <i>True</i>: Turn on <i>CrossPol Mode</i> • <i>False</i>: Turn off <i>CrossPol Mode</i> 	
	<i>Switch Port</i>	<p>On a Single Port Decimator, the value will be set to 0 and disabled. On a Multiport Decimator, the values will be from 1 to 4 or 8. This is the same as the <i>Switch Port</i> menu item on the <i>System</i> menu. It is provided here for convenience.</p>	
	<i>CrossPol Switch Port</i>	<p>On a Single Port Decimator, the value will be set to 0 and disabled. On a Multiport Decimator, the values will be from 1 to 4 or 8.</p>	
	<i>Peak Marker Mode</i>	<p>Whether or not the peak markers are locked at the peak power value and evaluated each time the trace changes, or draggable, which sets the peak markers at the peak power value only after the first trace acquisition, and allows you to drag the Peak Markers to another frequency.</p> <ul style="list-style-type: none"> • <i>Peak Lock</i> (default) • <i>Draggable</i> 	

Button	Menu Item	Description
<i>Carrier Monitor</i>	<i>New Measurement</i>	Create a new measurement using the current state of the Decimator. Provide a name and specify which analysis to run.
	<i>Measurement Delay</i>	The measurement delay in seconds. This is the time to wait between successive measurements.
	<i>Log Database Name</i>	<p>The output database name for traces and analysis files. If blank, logging will not occur. Serialization of data requires an external database to be installed. See Appendix A.</p> <p>The format of this string is as follows:</p> <p>Style 1 (Local Storage In Browser Cache, Not recommended)</p> <ul style="list-style-type: none"> • Plain string like “myDB” • This will store things in the browser cache. Useful for quick testing and serialization when getting familiar with Spectator or Detector. • For example, Chrome can store max 3GB of data or 3 days. Other browsers support a smaller amount. <p>Style 2 (External DB, Recommended)</p> <ul style="list-style-type: none"> • Enter some string in the following format https://user:password@ipaddress:sslPort/dbName • For example https://admin:password@192.168.20.3:6984/myDb • where <ul style="list-style-type: none"> ○ https = we are using Hypertext Transfer Protocol Secure or SSL ○ user and password = the same as the command line options passed into the SpectatorCouchDb docker container ○ ipaddress = IPV4 internet address of the host computer of the spectator Couch DB docker container, i.e. 192.168.20.3 or localhost ○ sslPort = 6984 or whatever is exposed on the docker container external port for SSL ○ dbName = any string you want to store the information in the database under. This will be the root node within the DB Viewer
	<i>Log File Lifespan</i>	<p>The length in days to preserve log files written in the log directory. If the value is set to something greater than 0, for example 4, log files older than 4 days will be purged. The Decimator will check the browser's cookies during the 0th hour in the day only, to so as not to continually access the disk. 1 day is the minimum since the <i>Spectator</i> application uses this for historical analysis. You will want to set this to something closer to 7 days if you are planning to use the historical analysis portion of the <i>Spectator</i> application.</p> <ul style="list-style-type: none"> • 7 (default): Purge any data that is older than 7 days • 1 to 7: The number of days to preserve log files

Button	Menu Item	Description		
	<i>Email</i>	<p>An edit window to specify:</p> <ul style="list-style-type: none"> • <i>Master Switch</i>: Enables email • <i>Mail Server</i> <ul style="list-style-type: none"> ○ <i>Name/Port</i>: Email server names like <i>smtp.gmail.com</i> can only be used with DHCP based networking. If required for use with a fixed IP address, use a simple email forwarding server like postfix. • <i>Authentication</i> <ul style="list-style-type: none"> ○ <i>None</i> ○ <i>SSL</i> <ul style="list-style-type: none"> ▪ <i>User name/Password</i> ○ <i>TLS</i> <ul style="list-style-type: none"> ▪ <i>User name/Password</i> • <i>From</i> <ul style="list-style-type: none"> ○ <i>Email/Name</i> • <i>Recipients</i> <ul style="list-style-type: none"> ○ <i>Email/Name</i> ○ <i>Style</i> <ul style="list-style-type: none"> ▪ <i>Simple Text</i>: Text only ▪ <i>Rich HTML</i>: Text and screen shot <p>Note: Ensure nothing is blocking port 25, such as virus software. You will need to remove or disable that port blocking for email to work.</p>		
	<i>SNMP</i>	<p>An edit window to specify:</p> <ul style="list-style-type: none"> • <i>Master Switch</i>: Enables SNMP • <i>Trap Destinations</i> <ul style="list-style-type: none"> ○ <i>IP Address</i> ○ <i>Port</i> ○ <i>Community</i> • <i>Test</i>: Select a trap destination and click the test button to send a SNMP trap with dummy values. 		
	<i>Analyses</i>	<p>All the Analyses that can be performed by carrier monitoring.</p> <table border="1" style="width: 100%; border-collapse: collapse;"> <tr> <td style="width: 20%;"><i>Band Power</i></td> <td> <p>Display submenus for the default band power analysis.</p> <ul style="list-style-type: none"> • <i>Nominal Power</i>: Edit the default nominal power in dBm • <i>Tolerance Power</i>: Edit the default tolerance power in dB <p>Algorithm:</p> <ul style="list-style-type: none"> • Compute band power from start to stop frequency for(all power values) </td> </tr> </table>	<i>Band Power</i>	<p>Display submenus for the default band power analysis.</p> <ul style="list-style-type: none"> • <i>Nominal Power</i>: Edit the default nominal power in dBm • <i>Tolerance Power</i>: Edit the default tolerance power in dB <p>Algorithm:</p> <ul style="list-style-type: none"> • Compute band power from start to stop frequency for(all power values)
<i>Band Power</i>	<p>Display submenus for the default band power analysis.</p> <ul style="list-style-type: none"> • <i>Nominal Power</i>: Edit the default nominal power in dBm • <i>Tolerance Power</i>: Edit the default tolerance power in dB <p>Algorithm:</p> <ul style="list-style-type: none"> • Compute band power from start to stop frequency for(all power values) 			

Button	Menu Item	Description	
			<pre>{ totalPower += 10.0^(power/ 10.0); }</pre> $\text{bandPower} = 10 * \log_{10}(\text{totalPower})$
		<i>Presence of a Carrier</i>	Display submenu for the default presence of a carrier analysis. <ul style="list-style-type: none"> <i>Delta Power</i>: Edit the default delta power in dB Algorithm: <ul style="list-style-type: none"> Measure max and min power $\text{DeltaPower} = \text{abs}(\text{maxPower} - \text{minPower})$
		<i>EIRP</i>	Display submenu for the default EIRP analysis. <ul style="list-style-type: none"> <i>Gain to Satellite</i>: Edit the default gain to satellite in dB <i>Nominal Power</i>: Edit the default nominal power in dBW <i>Tolerance Power</i>: Edit the default tolerance power in dB Algorithm: <ul style="list-style-type: none"> $\text{EIRP} = \text{BandPower} + \text{gainToSatellite} - 30$
		<i>CN</i>	Display submenu for the default C/N analysis. <ul style="list-style-type: none"> <i># Pwr Points to Avg (+/-)</i>: Edit the default \pm number of power points to average <i>Nominal Power</i>: Edit the default nominal power in dB <i>Tolerance Power</i>: Edit the default tolerance power in dB Algorithm: <ul style="list-style-type: none"> Find max power and average number of points around that Find min power and average number of points around that $\text{CN} = \text{avgMaxPower} - \text{avgMinPower}$
		<i>SNR</i>	Display submenu for the default signal to noise ratio analysis. <ul style="list-style-type: none"> <i>Min SNR</i>: Edit the minimum SNR Algorithm: <ul style="list-style-type: none"> Compute constellation demapping error <ul style="list-style-type: none"> $E = \sqrt{\text{sum}((\text{abs}(s - s_i))^2)}$ $\text{SNR} = f(E)$

Button	Menu Item	Description	
		<i>Center Frequency</i>	Display submenus for the default center frequency analysis. <ul style="list-style-type: none"> <i>Edge dB Drop</i>: Edit the amount the peak power will drop to define the edge of carrier in dB <i>Tolerance Frequency</i>: Edit the default tolerance power in Hz Algorithm: <ul style="list-style-type: none"> Find peak power Drop edge dB drop from peak to find carrier edges CF = Compute frequency midpoint between carrier edges
		<i>Carrier Power</i>	Display submenus for the default carrier power analysis. <ul style="list-style-type: none"> <i>Edge dB Drop</i>: Edit the amount the peak power will drop to define the edge of carrier in dB <i>Nominal Power</i>: Edit the default nominal power in dBm <i>Tolerance Power</i>: Edit the default tolerance power in dB Algorithm: <ul style="list-style-type: none"> Find peak power Drop edge dB drop from peak to find carrier edges <pre> for(all power values in that range) { totalPower += 10.0^(power/ 10.0); } carrierPower = 10 * log10(totalPower) </pre>
	<i>QoS Report</i>	When there are measurements and a log database name is set, this button will be enabled. It displays a dialog to collect how many days and for which measurements the quality of service report is to be run for. Then it displays the results, indicating the carrier's down time and quality of service (%).	
	<i>ACE - Automatic Carrier Extraction</i>	Show a dialog of settings to be configured before running automatic carrier extraction. It is recommended to set a low RBW value to get accurate results. Once these have been set and the command sent, a dialog containing a table of all the carriers found to match the requirements is displayed. You can edit the found carriers names, center frequency, span, band power, and band power tolerance before selecting carriers to be added to the measurements.	

Button	Menu Item	Description
Overview	<i>Overview Mode</i>	<p>The overview mode settings.</p> <ul style="list-style-type: none"> • <i>Off</i> (default) • <i>On Full Span</i> • <i>On 1 to On 8</i> <p>Setting the value to <i>On Full Span</i> makes the overview bar and <i>Refresh</i> buttons visible on the screen. It also acquires an overview trace and displays it on the overview bar.</p> <p>The overview bar is also visible in <i>On 1 to On 8</i> options. Each one of these options corresponds to an <i>Overview State</i>. This allows you to configure the overview bar to show a sub-segment of the entire span that corresponds to your specific needs. For example, the entire full span can include 3 or 4 transponders. Setting the upper plot area to show the span of one transponder allows that configuration of settings to be saved to an <i>Overview State 1 to 8</i>. This provides more granularity to see carrier details from a high level than just with the <i>On Full Span</i> option. See the <i>Overview</i> menu buttons below.</p>
	<i>Refresh</i>	<p>Refreshes the overview bar by acquiring a new trace. Enabled if the <i>Overview Mode</i> is <i>On Full Span</i> or an <i>On 1 to On 8 Overview State</i>.</p>
	<i>Overview State 1 to Overview State 8</i>	<p>Store the current state to one of the eight overview states. When the state is captured, a paperclip icon is displayed on the menu item.</p> <ul style="list-style-type: none"> • <i>Clear</i>: Clears the <i>Overview State</i> • <i>Capture</i>: Stores the current state as an <i>Overview State</i> • <i>View</i>: View the stored <i>Overview State</i> in a display dialog • <i>Name</i>: Name the <i>Overview State</i>. The name will appear on the menu item and on the <i>Refresh</i> button on the overview bar. Try to keep the number of characters small to ensure the text fits on the button, and/or use a space to allow for line wrapping.
Masks	<i>Selected Mask</i>	<p>The selected mask setting.</p> <ul style="list-style-type: none"> • <i>Off</i> • <i>Mask 1 to Mask 10</i> <p>Setting the value to a particular mask will apply the current mask to the spectrum plot and the trace call. The mask lines will change color based on their status.</p>
	<i>Mask 1 to Mask 10</i>	<p>Masks can be applied to traces and show in a quick visual if the trace is within the set bounds of the mask. When the mask is stored in the system, a paperclip icon is displayed on the menu item.</p> <ul style="list-style-type: none"> • <i>Name</i>: Name the mask. The name will appear on the menu item and other locations the mask is being used. Try to keep the number of characters small to ensure the text fits on the button, and/or use a space to allow for line wrapping. • <i>Edit Mask</i>: Opens the mask editing mode on the right drawer. This mode replaces the usual drawer and can be closed by clicking the X icon in the top left. You can add, remove, and edit points on the upper and lower masks in this mode.

Button	Menu Item	Description
<i>Save/Open</i>	<i>Save Screen to PNG</i>	Save the screen to a PNG file. Displays a file name dialog. Saved files will go to the <i>Downloads</i> folder unless you have configured your browser to save downloads elsewhere.
	<i>Save Project</i>	Save the current settings, memory based traces, markers attached to memory based traces, and states to a project XML file. Displays a file name dialog. Saved files will go to the <i>Downloads</i> folder unless you have configured your browser to save downloads elsewhere.
	<i>Open Project</i>	Opens a saved project from file and loads the data into the Decimator GUI. The current settings, memory based traces, markers attached to memory based traces, and states are loaded from the project XML file.
	<i>Save Local Storage</i>	Opens a file name dialog. The current state will be saved to the browser's local storage and can be accessed between sessions.
	<i>Open Local Storage</i>	Opens a dialog displaying the list of saved local storage files. Selecting one opens the saved project file and loads the data into the Decimator GUI. The current settings, memory based traces, markers attached to memory based traces, and states are loaded from the saved local project file.
	<i>Manage Local Storage</i>	Opens a dialog that allows you to delete project files you have saved to local storage.
<i>Preset</i>	N/A	Sets the Decimator back to its default settings and clears any stored traces, states, and markers.

2.2.4.2.4 Advanced Settings

The *Measure* menu provides *FFT Window* and *Optimization* settings, which are not typically changed for most measurements but are available if desired.

The FFT window selections described in the following table provide expanded analysis capability.

FFT Window	Highest Side Lobe Level (dB)	Equivalent Noise Bandwidth (bins)	3.0 dB Bandwidth (bins)	Scallop Loss (dB)
Rectangular ¹	-13.0	1.00	0.89	3.92
Flattop ^{2,3}	-93.6	3.77	3.72	0.005
Blackman-Harris ¹	-92.0	2.00	1.90	0.83
Hamming ¹	-43.0	1.36	1.30	1.78
Hanning ¹	-32.0	1.50	1.44	1.42

References:

1. "On the Use of Windows for Harmonic Analysis with Discrete Fourier Transform", Fredric J. Harris, Proceedings of the IEEE, Vol. 66, No. 1, January 1978.
2. "Extremely Flat-Top Windows for Harmonic Analysis", Irini S. Reljin, Branimir D. Reljin, Veljko D. Papić, IEEE Transactions on Instrumentation and Measurement, Vol. 56, No. 3, June 2007".
3. "Technical Review, Windows to FFT Analysis", Brüel & Kjær, No. 3 1987.

The *Optimization* setting is included for legacy reasons and has no effect on D4.

2.2.4.3 Overview Bar

The overview bar is a navigational assistance feature to help you set center frequency and span more efficiently.

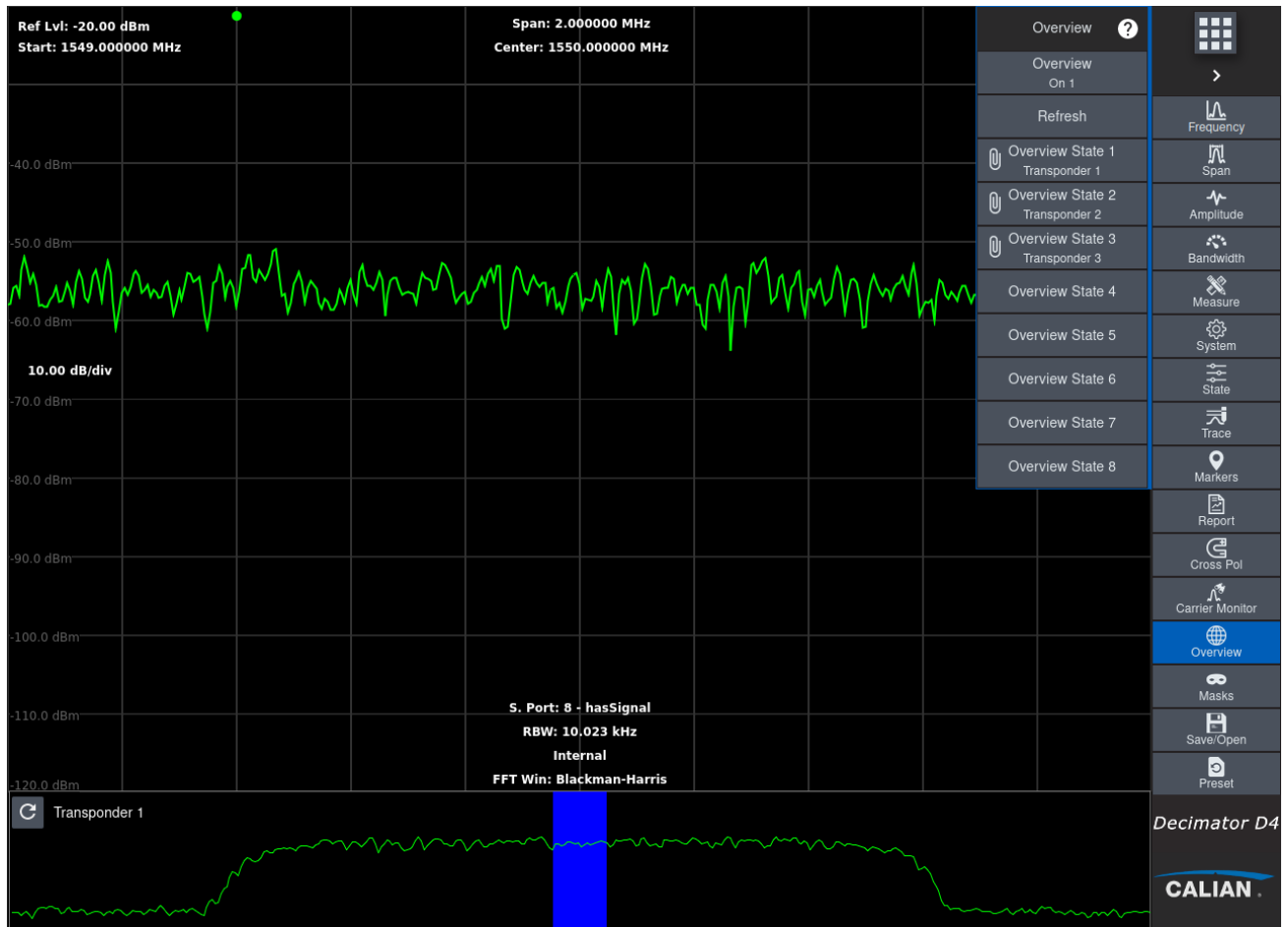

It is a full span bar that provides an overview of the entire spectrum; or with an *Overview State*, a view of a sub-segment of the entire span. This is ideal when trying to map to a transponder.

The blue selection block indicates the selected span for the trace in the plot area. The selection block can be dragged left or right to create a new center frequency in the plot area. The selection block edges can be dragged to create a new span and center frequency in the plot area. Moving the mouse on the overview bar updates the frequency on the mouse location bar and clicking the mouse sets the center frequency to that frequency. The overview bar full span trace can be refreshed manually with the *Refresh* button.

Overview states provide you with the ability to view a sub-segment of the entire span. For example, in a scenario where the entire full span of the Decimator contains three transponders named *Transponder 1*, *Transponder 2*, and *Transponder 3*, you can configure the overview bar to display *Transponder 1*, *Transponder 2*, *Transponder 3*, or the entire full span, and up to 5 more transponders when more come available. An *Overview State* is analogous to a measurement state.

The steps to configure the three-transponder scenario are as follows:

1. Set the center frequency, span, and RBW of the top display for *Transponder 1*.
2. From the *Overview* menu:
 - a. Click *Overview State 1*.
 - b. Click *Capture*.
3. Name the *Overview State 1*.
 - a. Click *Overview State 1*.
 - b. Click *Name*.
 - c. Enter: *Transp 1*.
4. Repeat the above three steps for *Transponder 2* and *Transponder 3*.
5. View *Transponder 1* in the overview bar by setting *Overview Mode* to *On 1*.
6. The overview bar is refreshed to show the entire *Transponder 1* span.
7. The overview bar is selected at center span with 5% of the entire span selected by default.
8. The transponder name *Transp 1* is displayed on the *Refresh* button.
9. You can then select carriers with the mouse.
10. The overview bar figure above depicts what the GUI looks like after these steps.

2.2.4.4 Cross-Polarity Mode

A Multiport Decimator can be configured in cross-polarity (CrossPol) mode where the Decimator displays the spectrum from two inputs simultaneously. In the example below, the blue trace *Switch Port*, is configured as 1 - *port1* and the orange trace *CrossPol Switch Port*, is configured as 2 - *port2*. The input port names default to *portX* where X is 1 to 8. These names can be changed through the configuration *Port Names* tab. CrossPol markers display the C/No delta power between the marker pair within each trace, as shown below in the legend.

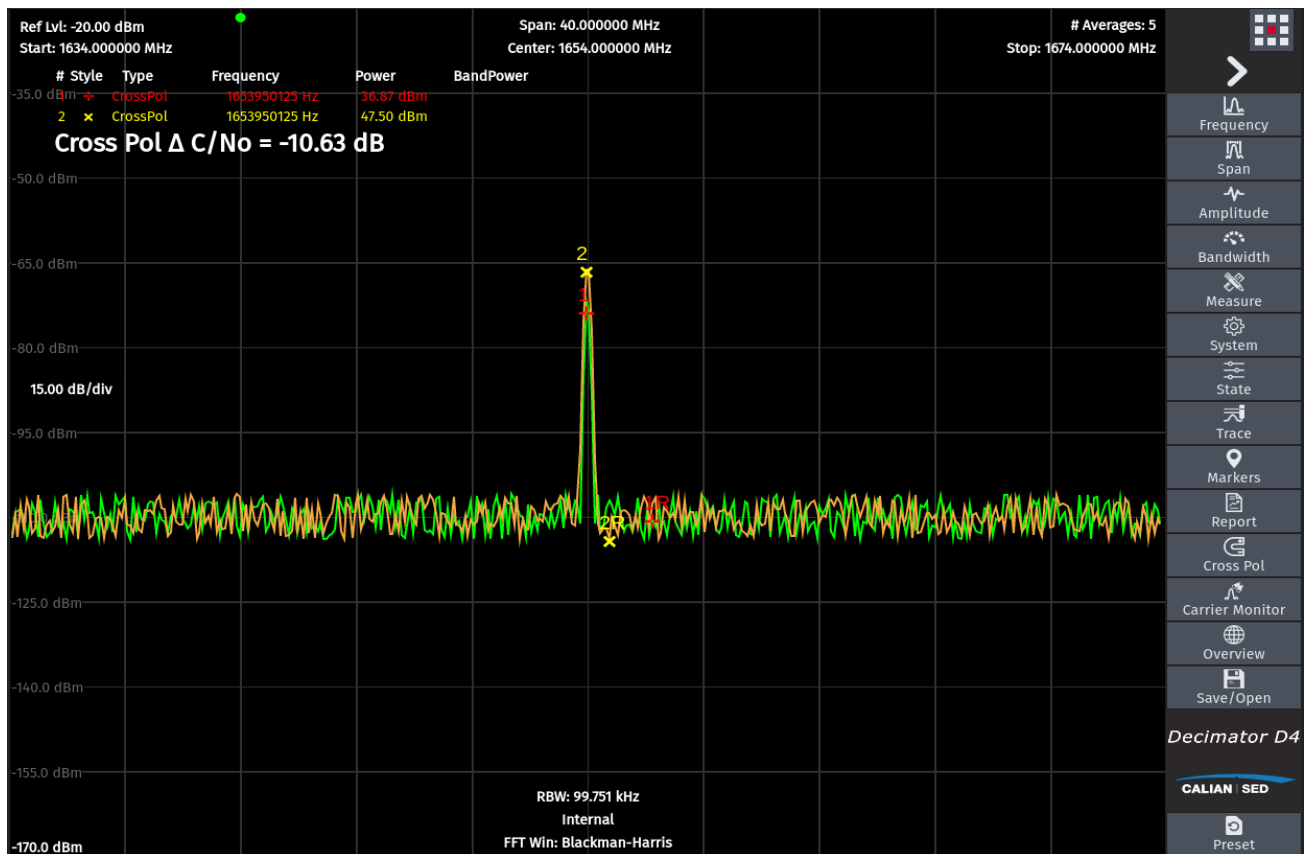

The *CrossPol* submenu provides the following settings:

- *CrossPol Mode* toggles whether or not the Decimator is in CrossPol mode.
- *Switch Port* determines where the active trace originates.
- *CrossPol Switch Port* determines where the CrossPol trace originates.
- *Peak Marker Mode* toggles whether or not you can drag all of the markers on the screen or just the ones suffixed with a -R. In *Peak Lock* mode, the two markers will move to the peak of the trace. In *Draggable*, the markers will stay where you position them.

2.2.4.5 Masks

Masks allow a user to quickly see if the power of the trace leaves the set bounds by the upper and lower masks. The following image is an example of editing a specific mask, in this case *Mask 1*.

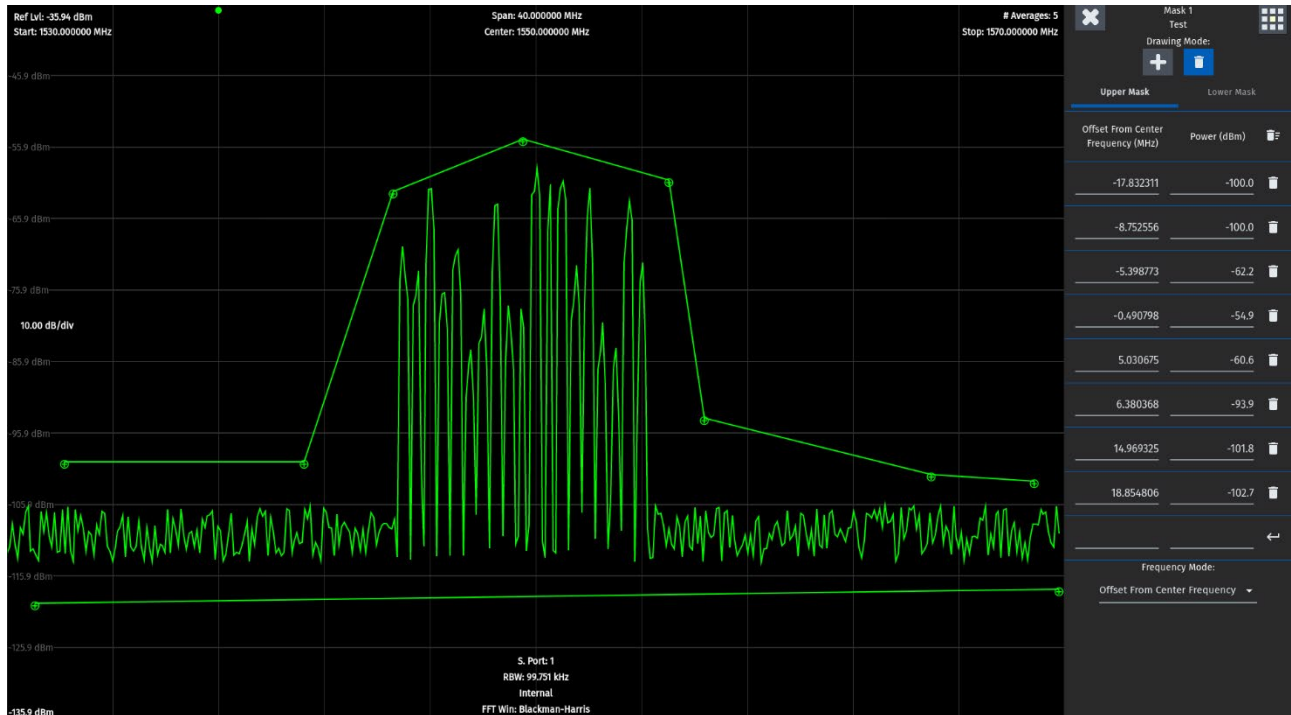

The mask editor has two drawing modes: add and delete. Adding allows points to be defined by clicking on the spectrum plot while deleting allows the point nearest to the user's click on the spectrum plot to be removed. You can select which bound to edit by clicking the *Upper Mask* or *Lower Mask* tabs directly below the drawing mode buttons. Finally, you can enter, edit, and delete lines by modifying the points table.

It is important to note that masks are stored with frequencies relative to the center frequency. Therefore, what is being configured is a mask template. A mask is typically defined for a particular carrier shape. Since many carriers exist of a specific carrier type, you can apply this mask template at any frequency; however, we recommend span remains the same.

2.2.4.6 Carrier Monitor

The Decimator can be configured to monitor up to 2000 carriers, validating the captured trace for limits within acceptable *Band Power*, *Presence of a Carrier*, *EIRP*, *C/N*, *SNR*, *Center Frequency*, *Carrier Power*, *Mask*, *CW Frequency*, and *CW Power* analyses thresholds. The measurement is defaulted to use the entire span of the viewport. If configured, the carrier monitoring system will email users when an alarm threshold is exceeded. If configured, the carrier monitoring system will send SNMP trap notifications to a trap receiver, which is handy when wanting to log actual measurement analysis results for each measurement. To use the carrier monitoring system, a new measurement must be configured then enabled.

2.2.4.6.1 New Measurement

The following figure shows the *New Measurement* window.

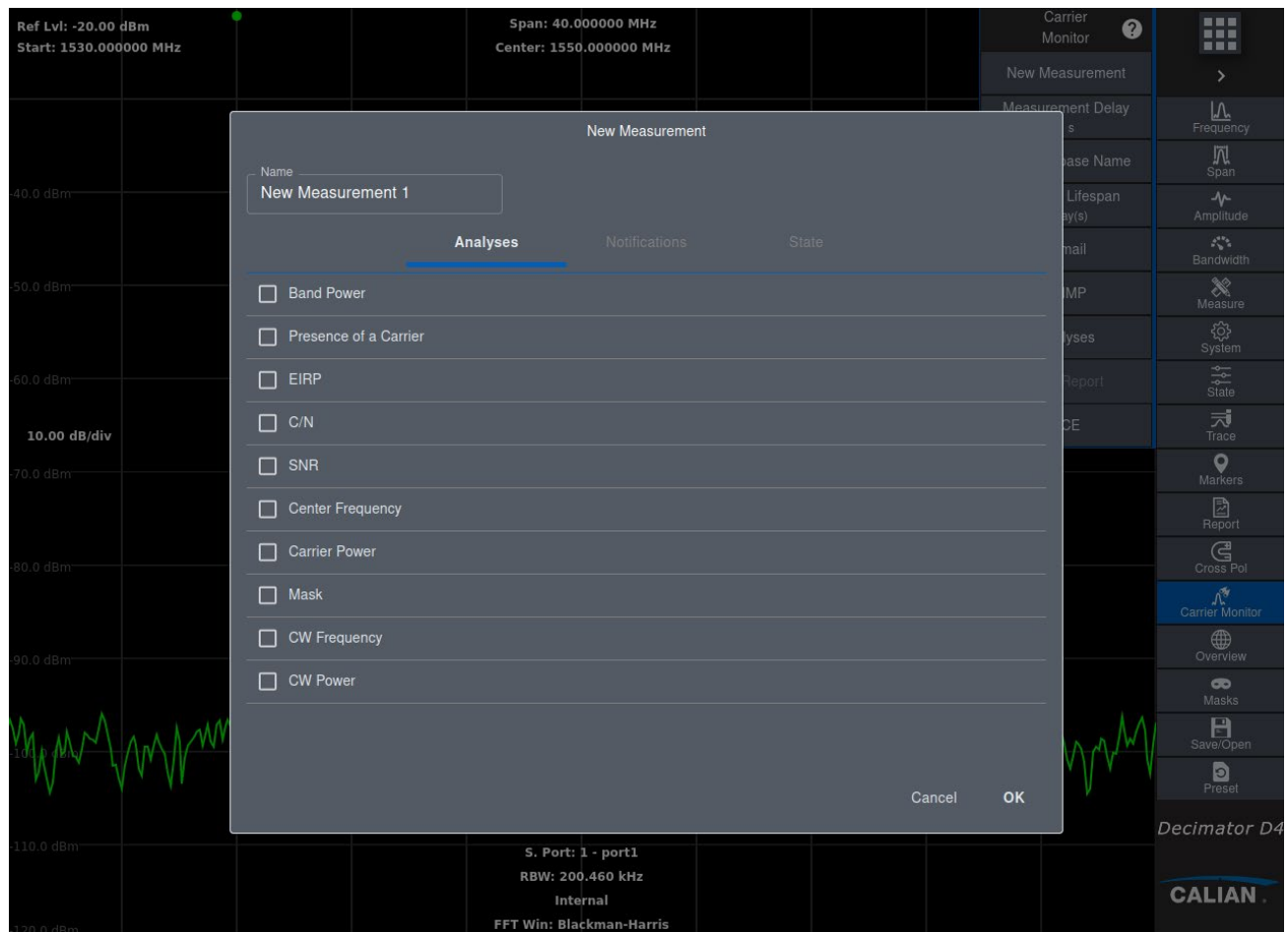

To add a measurement:

- Click the *Carrier Monitor* button
- Click the *New Measurement* menu item

- On the *New Measurement* display:
 - Enter a unique carrier name.
 - Specify the analysis or analyses to perform.
 - Specify the threshold parameters by accepting the default ones or overriding them.
 - Click *Ok*.
- The measurement is added to the table in the *Carrier Monitor* toolbar.
- Alternatively, click on the *Add* button on the *Carrier Monitor* toolbar.







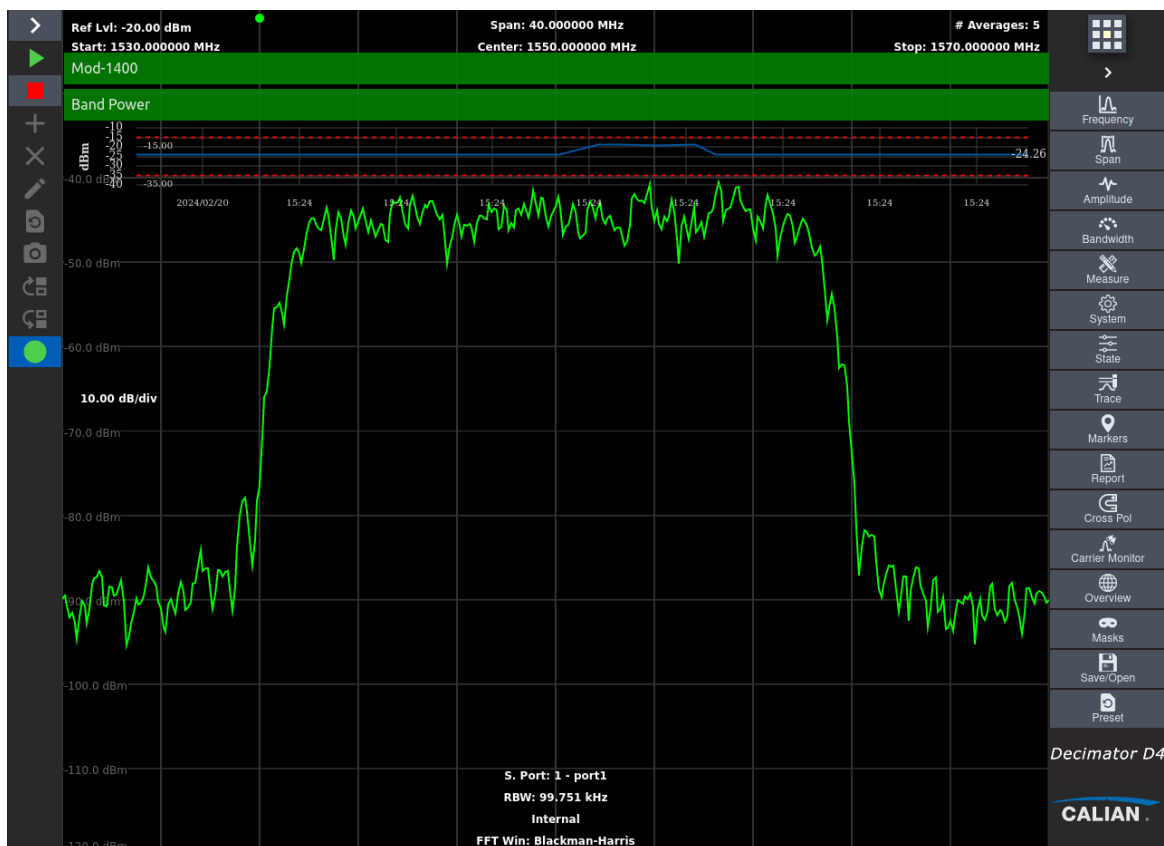



A unique name must be given to each new measurement. Use the tabs to configure the options for *Analyses*, *Notifications*, and *State*. The state options are not configurable through this menu. These values are determined from the current configuration.

2.2.4.6.2 Carrier Monitor Toolbar

The *Carrier Monitor* toolbar appears after one or more measurements have been configured. Click the > button in the toolbar to widen it, making the measurement names visible. The following figure shows one carrier monitor measurement configured in the toolbar. Note that the measurement has been played so many of the carrier monitor toolbar buttons have been disabled. The selected carrier (*Mod-1400* from the *Measurement Table*) can have up to 24 hours of results displayed in the *Carrier Monitor* window.



The following table describes each of the *Carrier Monitor* toolbar buttons.

Button Name	Button Graphic		Description
Play			Start the carrier monitor. This will sequentially process the carrier monitor measurements. If a threshold is exceeded, the measurement status LED will go red and, if enabled, a notification will be sent.
Stop			Stop the carrier monitor measurements.
Add			Create a new measurement.
Delete			Delete the selected measurement.
Edit			Edit the selected measurement.
Recall State			Recall the Decimator state from the measurement.
Capture State			Capture the state of the Decimator to the selected measurement.
Move Measurement Down			Move the selected measurement down one.
Move Measurement Up			Move the selected measurement up one.
Measurement Table		or	<div style="border: 1px solid gray; padding: 5px; width: fit-content;"> <ul style="list-style-type: none"> ● Carrier 1 ● Carrier 2 ● Carrier 3 </div> <p>When the carrier monitor toolbar area is collapsed, only the measurement status LED is shown. Expanding the toolbar allows both the <i>Measurement Status</i> and <i>Measurement Name</i> to be shown.</p> <p>Hovering the mouse over a measurement will cause a tool tip to be displayed with the <i>Measurement Name</i>.</p> <p>LED: Gray is unknown, green is success, red is failure.</p>

To start playing in carrier monitor mode, click the play button. The current measurement state will be set, a trace acquired, analyses run, measurement status evaluated and displayed, optional logging of results and any notification(s) raised if necessary. A measurement overlay is added to the screen in the upper left indicating the current measurement in progress. The *Measurement Table* updates the selection. The overlay contains up to 24 hours of historical data for each analysis configured. Each analysis is evaluated and its status is reflected in the caption bar through color.

To stop playing in carrier monitor mode, click the stop button.

To delete a measurement, select the measurement and click the delete button.

To edit a measurement, select the measurement and click the edit button. Then modify the measurement's *Analyses* or *Notification Events*. The current state of the Decimator will be used to overwrite the measurements state. Recalling state prior to editing a measurement is recommended if no change in state is desired.

To recall the state of a measurement, select the measurement and click the recall state button.

To capture state to the selected measurement, select the measurement and click the capture state button.

2.2.4.6.3 Carrier Monitor Notifications

The carrier monitor system can be configured to send emails (non-secure, SSL, or TLS) when measurements exceed user-specified limits. A measurement is marked as failed when an individual analysis for a given measurement is found to be outside of its tolerance range. The carrier monitoring system can be configured to send SNMP traps to an external trap receiver regardless of measurement state, making it an ideal mechanism to log analysis results.

Email notifications are raised if and only if:

- The master email switch is on, and
- The individual email notification is on within the measurement, and
- There is a status change in the measurement.

SNMP traps are raised if and only if:

- The master SNMP switch is on, and
- The individual SNMP notification is on within the measurement

2.2.4.6.4 Automatic Carrier Extraction (ACE)

The Automatic Carrier Extraction assists in adding new measurements for carrier monitoring.

2.2.4.6.4.1 ACE Inputs

The following figure shows the *ACE Inputs* configuration dialog.

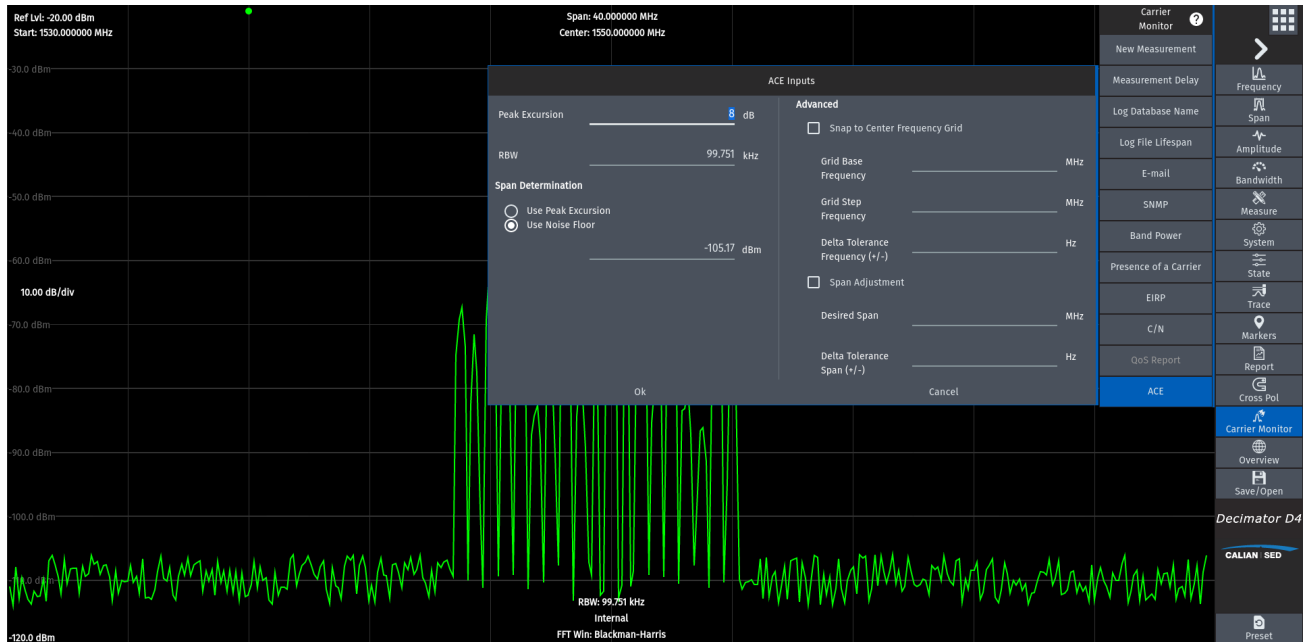

In the example screen above, the plot area has 19 carriers in view, which will be the carriers the ACE extracts.

The *ACE Inputs* dialog allows you to set the following:

- *Peak Excursion* is the minimum change in dB a carrier needs to rise and fall before it counts as a carrier by the ACE algorithm. This is used for determining the span of the carrier. However, *Peak Excursion* does NOT guarantee the midpoint is the peak of the carrier. To use *Peak Excursion* for the algorithm, ensure the *Use Peak Excursion* radio button is selected.
- *Noise Floor* is the base from where the value rises. Spans determined with the *Use Noise Floor* option are required to touch or pass the noise floor on both sides of a carrier in order to be selected by the algorithm.
- *RBW* allows you to set a temporary RBW to be used while the ACE window is displayed and for the extraction. A low RBW is recommended to ensure an accurate result for the nominal band power. A high RBW will make the band power result inaccurate.

- *Snap to Center Frequency Grid Advanced* setting ensures that only carriers with a center frequency within a set range are selected and displayed, as per the diagram below.

Accepted Carrier

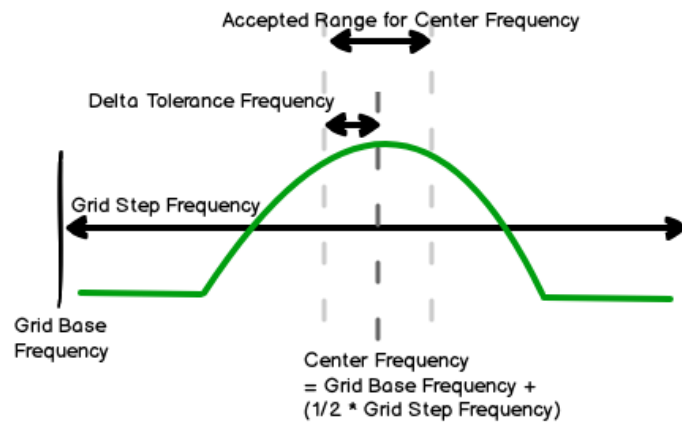

Rejected Carrier

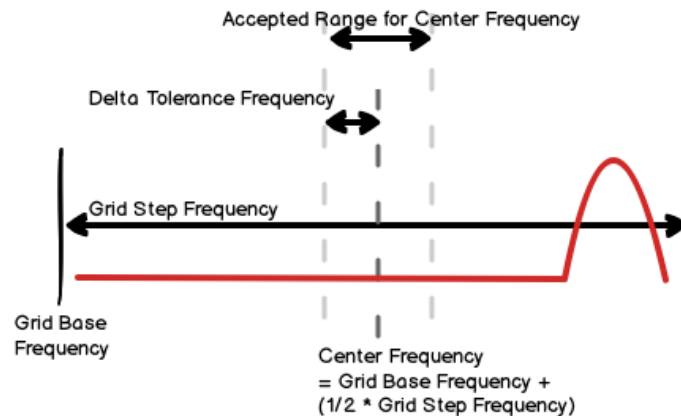

- *Span Adjustment Advanced* setting ensures that the spans of the found carriers are within a tolerance, as per the diagram below.

Accepted Carrier

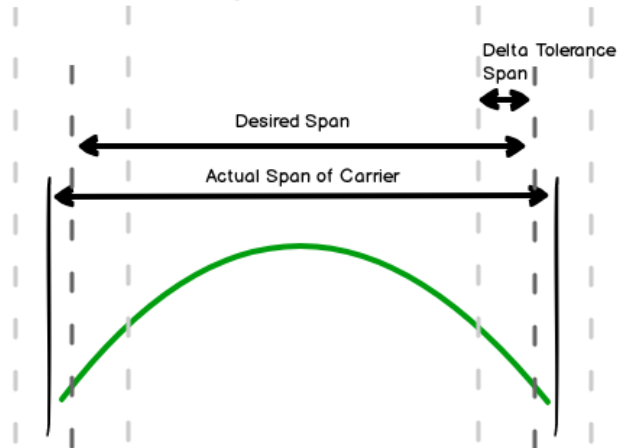

Rejected Carrier

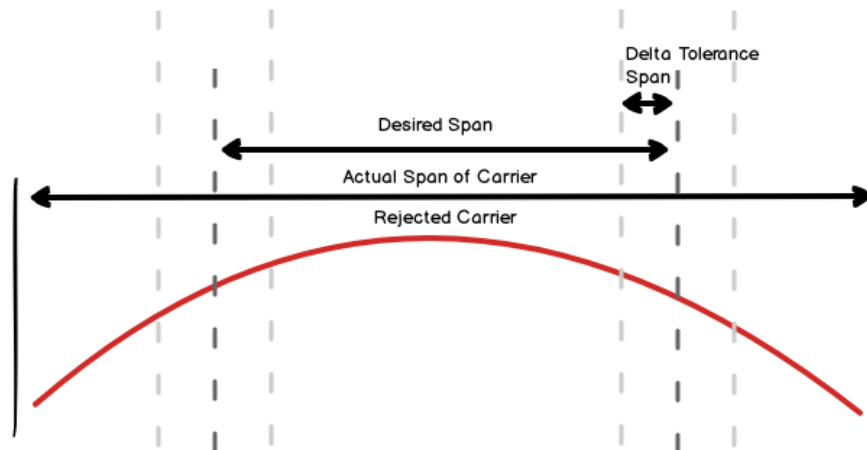

For example, if a carrier is found with a span of 1000 Hz, with a desired span set to 500 Hz and a tolerance of 200 Hz, that carrier will not be displayed on the found carriers screen.

Prior to running the ACE command, the entered data will be validated to ensure there are no empty fields or invalid entries. If there are errors, an error message will be displayed and the *Ok* button will cause the Decimator to stay on the screen until you have addressed the errors.

2.2.4.6.4.2 ACE Found Carriers

After you submit the configuration settings, a processing screen will appear followed by the dialog shown below. The dialog displays all of the found carriers that match the advanced settings, as shown below.

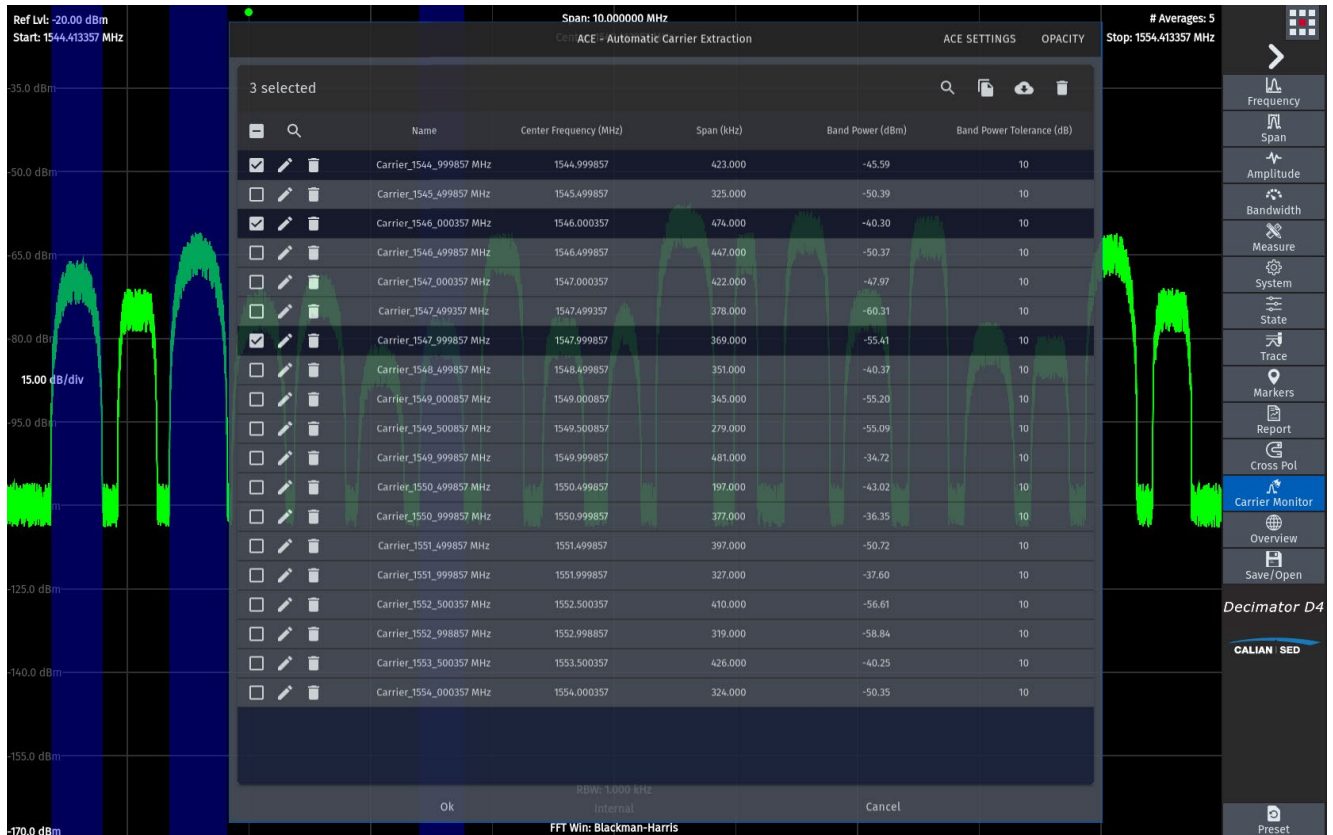

You can edit the rows by clicking the pencil icon to adjust any of the fields. Ensure that all carrier names in the table are unique to each other and to already created measurements. Trying to add a carrier with a duplicated name will cause an error to be displayed.

Selecting a row highlights the carrier on the plot area in blue. Only the carriers that are selected will be submitted into carrier monitoring when the *Ok* button is clicked.

The opacity button at the top left can be used to change the opacity of the dialog to allow you to view both the table information and the selected carriers.

2.2.5 Spectator/Detector

The *Spectator or Detector* functionality is an extension to carrier monitoring that requires an additional license(s). *Spectator* provides a tiled display of up to 100 measurement traces (you can show more if your screen real estate allows it), state, and much more. *Detector* does the same, except with a constellation plot. If you have both licenses, you can toggle which view is shown, or see both at the same time.

2.2.5.1 Database Installation

Spectator/Detector requires an external database to be installed. See the detailed instructions in Appendix A. This step **must** be performed to ensure proper long-term storage of measurement data. It will take about 60 to 90 minutes to setup and requires a moderate knowledge of software installation. You may want to consult with your network administrator to have them prepare this for you as you will need to have administrator privileges for this.

2.2.5.2 Spectator/Detector Dashboard

The *Spectator or Detector* menu item is accessed from the apps button at the top right corner of the screen. Selecting the *Spectator or Detector* app causes the dashboard to appear as shown below. This displays an overview of the carriers that have been previously configured for carrier monitoring.

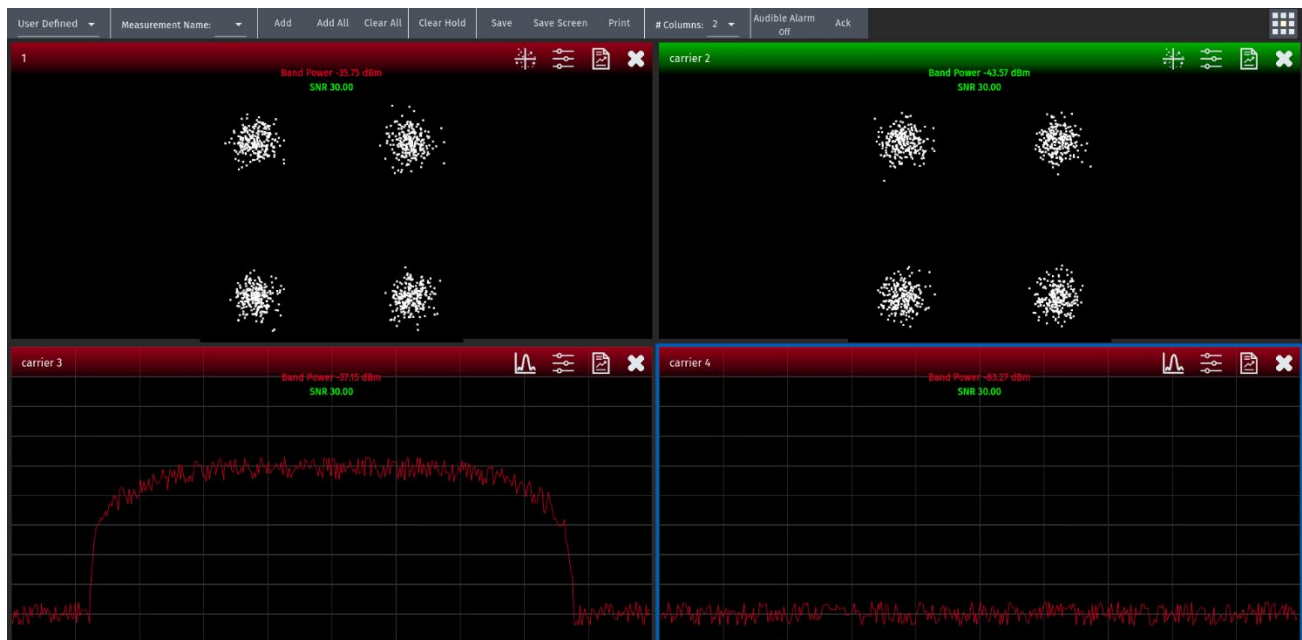

Each measurement can be added to the tiled display for up to 100 carriers. The trace for each measurement is shown in an individual tile and updated in real time. As each measurement is being performed, it is selected in a blue outline. When the measurement completes, the alarm state of the carrier is re-evaluated and colored according to the alarm state.

The screen consists of these areas:

- Toolbar at the top.
- Dashboard grid in the center.

2.2.5.2.1 Toolbar

The *Spectator* dashboard toolbar consists of a mode combo box. The mode can be one of the following:

- User-defined
- Active alarm
- Historical alarm

2.2.5.2.1.1 User-Defined Mode

User-Defined mode provides a customizable dashboard to add and remove measurements. The layout is statically defined by you, with the traces and status being dynamically updated by carrier monitoring.



When in this mode, the rest of the toolbar has the following items:

- *Measurement Name*: List of measurements defined in carrier monitoring.
- *Add*: Click this button to add the measurement to the dashboard display.
- *Add All*: Click this button to add all the measurements to the dashboard display.
- *Clear All*: Click this button to remove all the measurements from the dashboard display.
- *Clear Hold*: Click this button to clear all minimum and maximum hold trace lines from all measurements on the dashboard display.
- *Save*: Click this button to prompt for a file name to save the layout (user-defined measurements and number of columns) to the project file.
- *Save Screen*: Click this button to save the screen image to a PNG file.
- *Print*: Click this button to print the screen.
- *# Columns*: Set the number of columns in the dashboard.
- *Audible Alarm*: Click this button to toggle whether or not the browser will generate an audible alarm when a carrier goes from healthy to alarm state.
- *Ack*: Click this button to acknowledge the alarm and stop the audible alarm.

2.2.5.2.1.2 Active Alarm Mode

Active Alarm mode automatically configures the grid to display only measurements in alarm state. The Decimator removes a measurement immediately when goes out of alarm state. Measurements in the dashboard are ordered by most recently raised at the top left and proceed across the dashboard horizontally, then to the next row if need be.

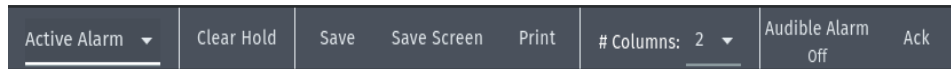

When in this mode, the rest of the toolbar has the following items:

- *Clear Hold*: Click this button to clear all minimum and maximum hold trace lines from all measurements on the dashboard display.
- *Save*: Click this button to prompt for a file name to save the layout (user-defined measurements and number of columns) to the project file.
- *Save Screen*: Click this button to save the screen image to a PNG file.
- *Print*: Click this button to print the screen.
- *# Columns*: Set the number of columns in the dashboard.
- *Audible Alarm*: Click this button to toggle whether or not the browser will generate an audible alarm when a carrier goes from healthy to alarm state.
- *Ack*: Click this button to acknowledge the alarm and stop the audible alarm.

2.2.5.2.1.3 Historical Alarm Mode

Historical alarm mode automatically adds all measurements in alarm state to the dashboard and any measurements that were raised within the *Since* time entry field. It removes them immediately when the measurement is out of alarm state and its raised time is beyond the *Since* time entry field. Measurements in the dashboard are ordered by most recently raised at the top left and proceed across the dashboard horizontally, then to the next row if need be. Non-alarmed measurements still within the *Since* time threshold appear last.







When in this mode, the rest of the toolbar has the following items:

- *Since* time value: Enter the time value. Must be numeric. Default is 12.
- *Since* time units: The time units, either days, hours, or minutes. Default is hours.
- *Update View*: When making a change to the *Since* time fields, click this button to refresh the dashboard view.
- *Clear Hold*: Click this button to clear all minimum and maximum hold trace lines from all measurements on the dashboard display.
- *Save*: Click this button to prompt for a file name to save the layout (user-defined measurements and number of columns) to the project file.
- *Save Screen*: Click this button to save the screen image to a PNG file.
- *Print*: Click this button to print the screen.
- *# Columns*: Set the number of columns in the dashboard.
- *Audible Alarm*: Click this button to toggle whether or not the browser will generate an audible alarm when a carrier goes from healthy to alarm state.
- *Ack*: Click this button to acknowledge the alarm and stop the audible alarm.

2.2.5.2.2 Dashboard Grid

The *Spectator/Detector* dashboard grid provides a grid of measurement tiles. Each tile consists of the following:

- **Title Bar**
 - The measurement name as text.
 - The measurement status in background color.
 - A series of buttons on the top right:
 - View toggle button: can be one of the following:
 - : shows spectrum plot view if *Spectator* is licensed
 - : shows constellation plot view if SNR measurement is configured and *Detector* is licensed
 - : shows both the spectrum plot and constellation plot
 - Historical button:  Click this to display the *Spectator/Detector* historic view.
 - Settings button:  Click this to display a dialog of the measurement settings, such as center frequency and span.
 - Close button: Click this to remove the measurement from the display. Only applicable in *User-Defined* mode.
- **Plot Area**
 - The trace is displayed.
 - Current analysis results are displayed at the top.
 - Double-click the plot area to display the *Spectator/Detector* historic view

The following image shows what a measurement tile configured to show both Spectrum and Constellation plots looks like.

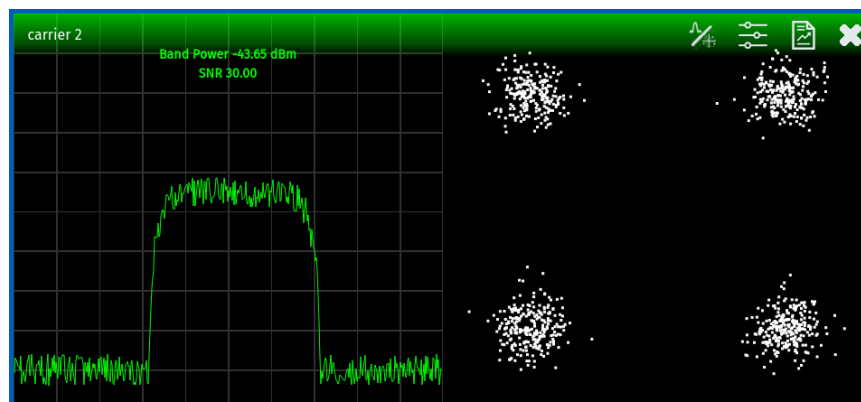

2.2.5.3 Spectator/Detector Historic View

The *Spectator/Detector* historic view allows the current analyzer settings of the measurement tile to be viewed along with historical trend of the measurement, in addition to the measurement trace for *Spectator* and constellation plot for *Detector*.

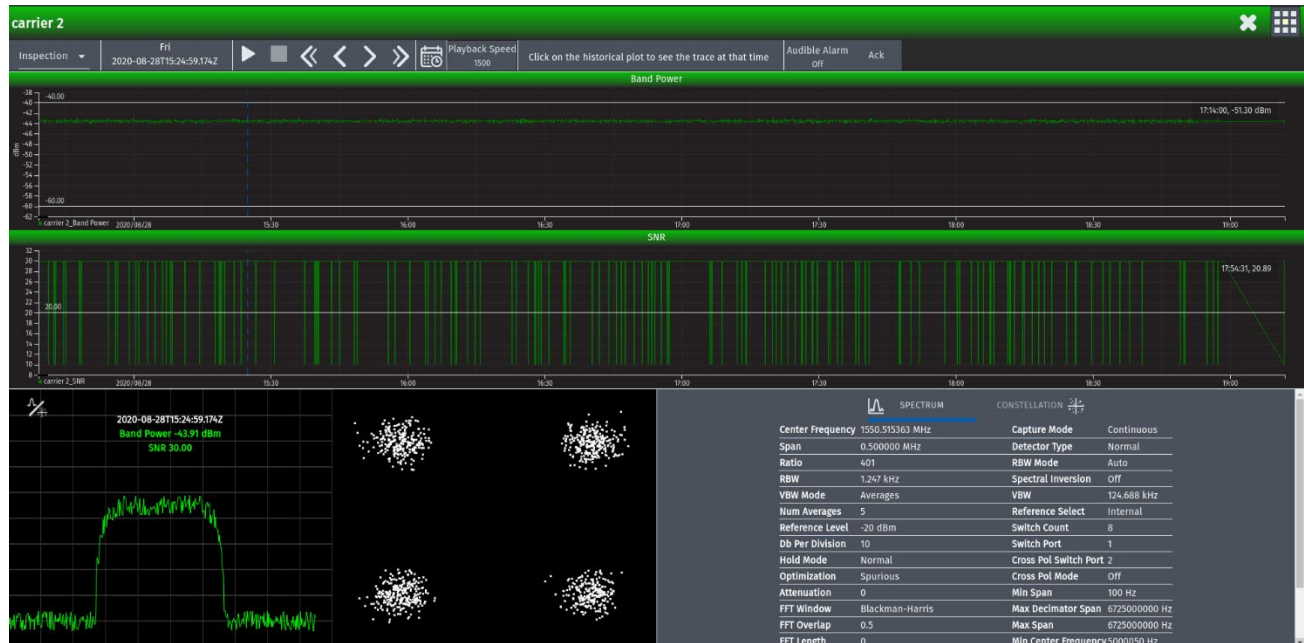

Carrier monitoring logging **MUST** be turned on for historic view to work. The view window works in a live update mode along with an inspection mode. In the live update mode, the trace updates in real-time as new traces are measured. The state of the measurement is re-evaluated and displayed along with an update to the trend portion of the window.

The screen consists of these areas:

- Carrier name title bar with hamburger button to toggle on and off historical analyses plots

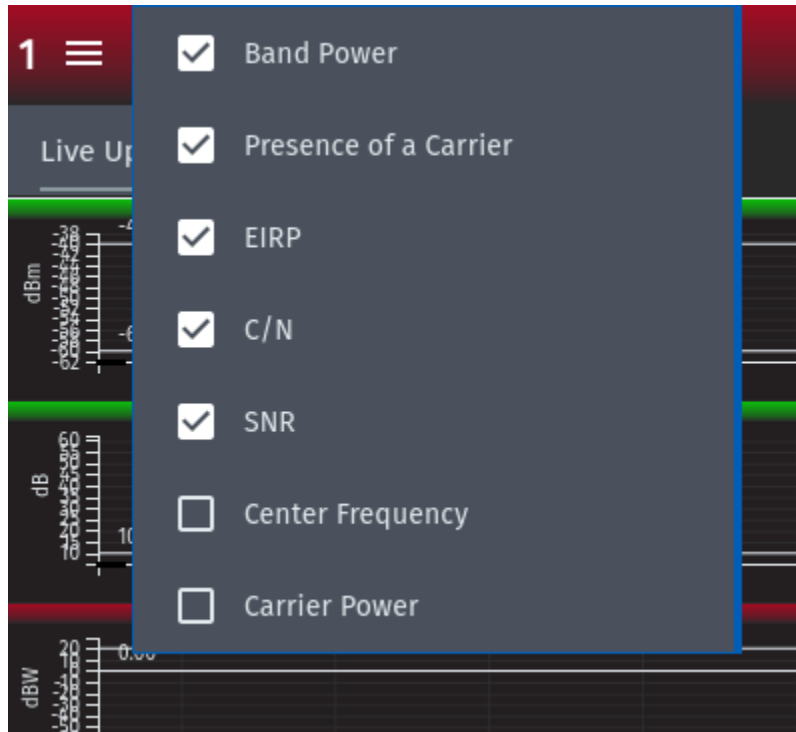

- Toolbar at the top
- Historical analyses plots in the middle
- Settings panel at the bottom right
- Trace plot and or constellation plot at the bottom left

2.2.5.3.1 Toolbar

The *Spectator* historic view toolbar consists of a mode combo box followed by the selected date label and mouse-over date label. The mode can be one of the following:

- *Live Update*
- *Inspection*

2.2.5.3.1.1 Live Update Mode

When you select *Live Update* mode, the Decimator shows the latest trace plot and continues to append analysis results to the historical analysis plots. The toolbar is empty other than the mode combo box.

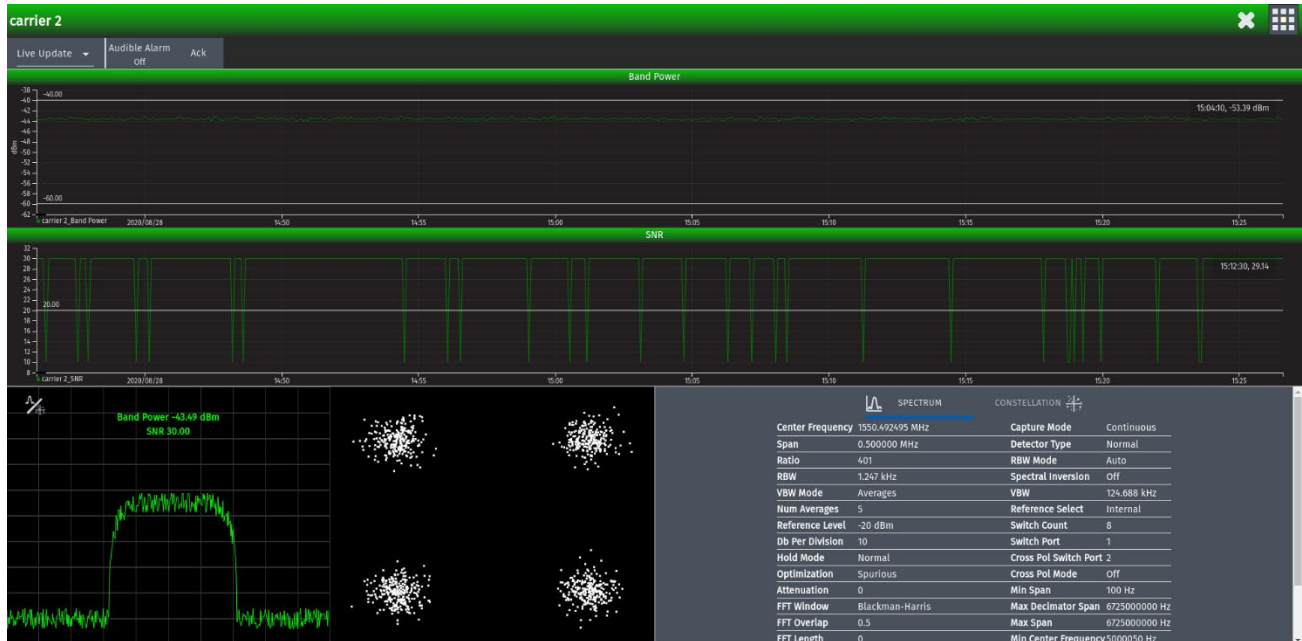

2.2.5.3.1.2 Inspection Mode

When you select *Inspection* mode, the Decimator displays one day of analysis results in the historical analysis plots.

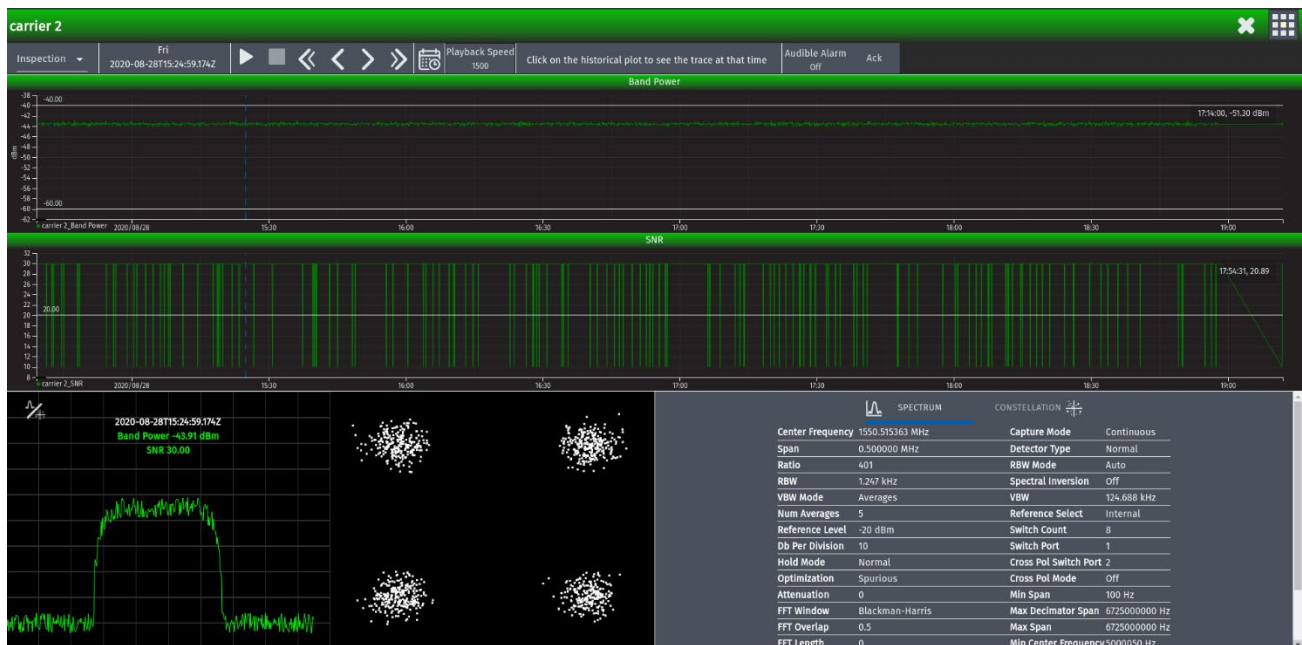

This mode also provides the ability to select a time by clicking in the historical analysis plots. The Decimator will display a blue vertical line on the historical analysis plots and update the trace plot with the trace at that time.



The rest of the toolbar provides the following items:

- **Selected time:** This shows the day and time of the selected time along with the day of the week
- **Play:** Click this button to play the simulation (1.5 seconds per time frame) of the traces starting from the currently selected time.
- **Stop:** Click this button to stop the simulation.
- **Go to First:** Click this button to select the first time in the historical analysis plots.
- **Go to Previous:** Click this button to select the previous time from the selected time in the historical analysis plots.
- **Go to Next:** Click this button to select the next time from the selected time in the historical analysis plots.
- **Go to Last:** Click this button to select the last time in the historical analysis plots.
- **Calendar:** Click this button to display a calendar. Select a day to display.
- **Playback Speed:** The playback speed in milliseconds. Defaults to 1500 ms. A smaller value will play faster. 1500 ms is the smallest value possible. Note that small values may not perform well on older computers.
- **Audible Alarm:** Click this button to toggle whether or not the browser will generate an audible alarm when a carrier goes from healthy to alarm state.
- **Ack:** Click this button to acknowledge the alarm and stop the audible alarm.

In inspection mode, live updates are turned off and the toolbar allows navigation to trend points of interest. The time period of the trend is displayed on the X-axis of the trend. Selecting a time displays the trace for that point in time and a vertical blue bar visually indicates the selected time on the trend plot.

In inspection mode, additional toolbar icons are available to allow a playback simulation to be performed. After clicking the play button, the traces are updated as the time point moves forward in time from the selected point. The stop button is used to stop the playback once started. The playback can also be performed manually using other toolbar buttons. You can load up to one day of log data by clicking on the calendar button and selecting the day. The amount of data you can store in the external database is dependent on the disk size of where you installed the database. You can also purge this data automatically after a number of days by setting the Log File Lifespan setting in the carrier monitoring menu to a positive number in days.

2.2.5.3.2 Historical Analysis Plots

This provides a historical trend plot over time of the analysis results. Threshold lines are added. In Inspection mode, a blue vertical line depicts the selected time.

2.2.5.3.3 Settings Panel

This panel provides the current settings of the measurement.

2.2.5.3.4 Trace Plot

This provides the trace either at the current time or selected time.

2.2.5.3.5 Constellation Plot

This provides the constellation plot either at the current time or selected time.

2.2.6 Waterfall

The *Waterfall* plot is a non-licensed Decimator feature. It provides a power vs frequency vs time view of the measurements the Decimator is collecting. The most recent data is displayed at the top of the plot.

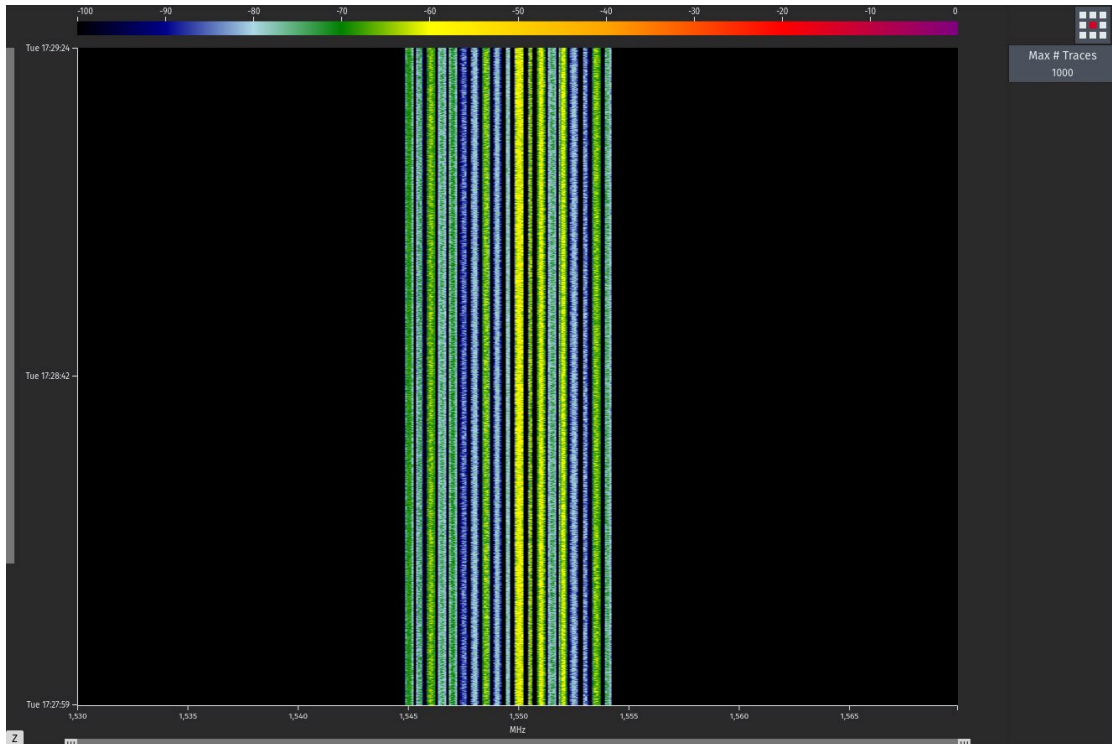

The scale, found at the top of the *Waterfall* display, is a heat map of power values. The plot data is cleared when you change a spectrum plot setting or the maximum number of traces. You can set how many traces the Decimator stores for the plot by using the *Max # Traces* button, which opens an edit dialog for you to enter a positive integer. Entering zero will pause the *Waterfall* updates.

2.2.7 Signal Analyzer

The *Signal Analyzer* functionality provides you with the ability to demodulate a trace and show the constellation plot and various line graphs.

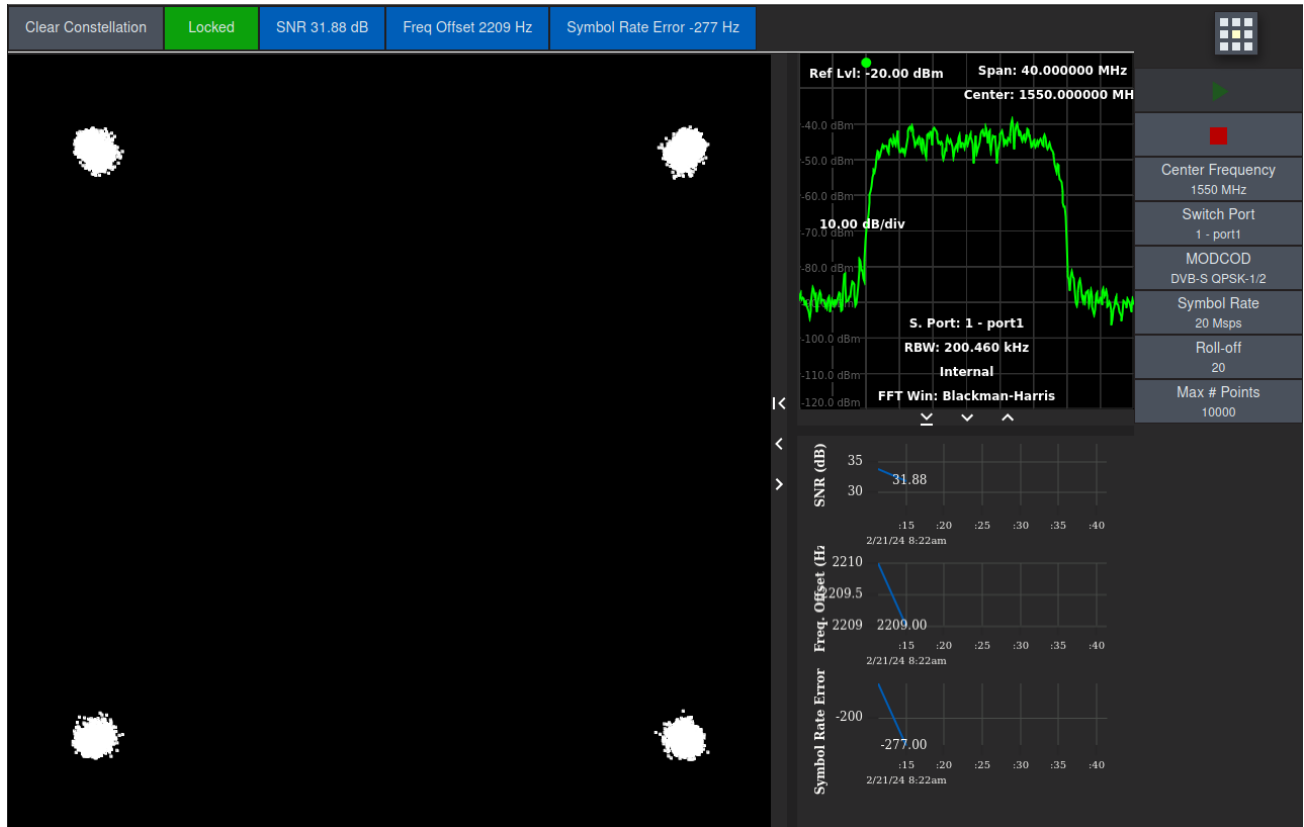

The screen consists of these areas:

- Toolbar at the top.
- Constellation plot at the left.
- Spectrum display near the top right.
- Demodulated signal statistics plots under the spectrum display.
- Menu buttons on the right side column.

The toolbar provides the following:



- *Clear Constellation* button to restart the plot.
- An indication of whether the signal is locked.
- Current numerical values of the demodulated signal statistics.

Clicking on a numerical value button along the top will add or delete the corresponding plot, changing the color of the button accordingly.

The following demodulated signal statistics are available:

- Signal-to-noise ratio (SNR) in dB.
- Frequency offset in Hz.
- Symbol rate error in Hz.

Menu buttons are provided as follows:

- Play:  Start demodulation.
- Stop:  Stop demodulation.
- *Center Frequency*: Set the center frequency in MHz.
- *MODCOD*: Select the modulation and coding standard.
 - DVB-S
 - QPSK (1/2, 2/3, 3/4, 5/6, 7/8)
 - DVB-S2
 - QPSK (1/4, 1/3, 2/5, 1/2, 3/5, 2/3, 3/4, 5/6, 8/9, 9/10)
 - 8QPSK (3/5, 2/3, 3/4, 5/6, 8/9, 9/10)
 - 16APSK (2/3, 3/4, 4/5, 5/6, 8/9, 9/10)
 - 32APSK (3/4, 4/5, 5/6, 8/9, 9/10)
- *Symbol Rate*: Set the symbol rate in MHz.
- *Roll-off*: Set the roll-off. *Max # Points*: Set the maximum number of data points to display in the constellation plot.

2.2.8 Carrier Under Carrier

The Carrier Under Carrier functionality is a licensed feature which visualizes interfering carriers hidden below the carrier of interest.

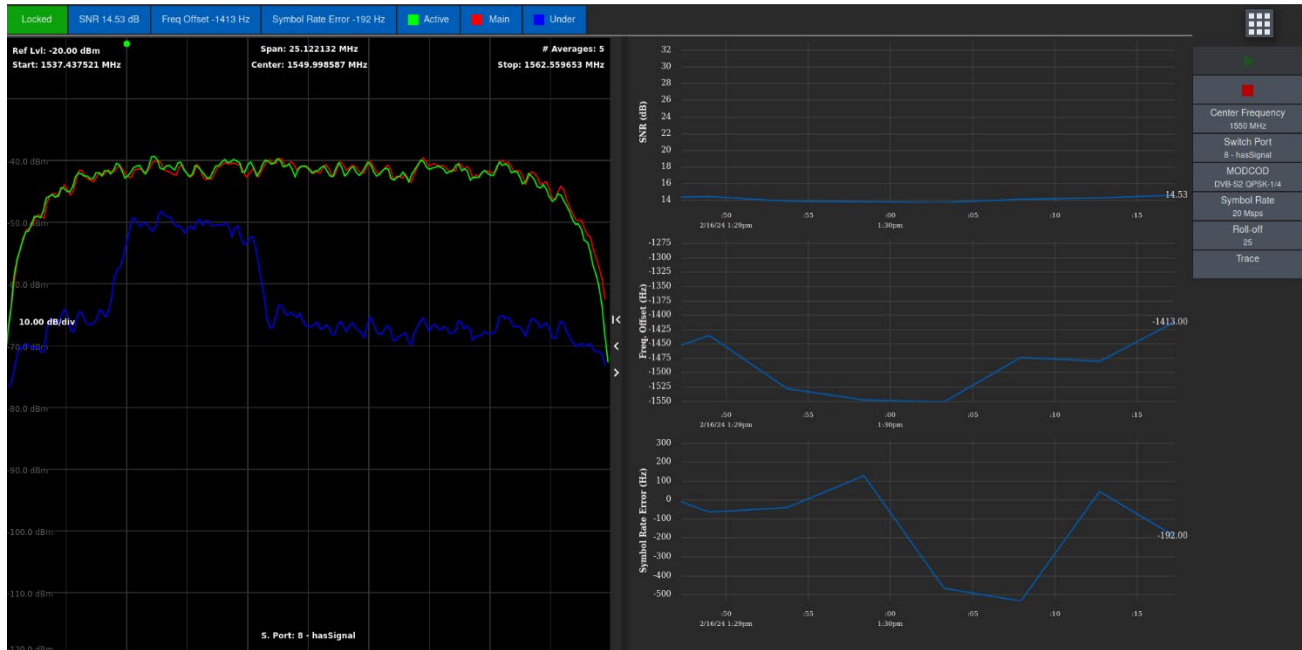

The screen consists of these areas:

- Toolbar at the top
- Multi-spectrum display at the left
- Statistics plots on the right
- Menu buttons on the right-side column



The toolbar at the top of the screen shows an indication of whether the signal is locked, the reported statistics for the signal, and control buttons to show and hide the traces. Clicking on the statistics will add or remove the corresponding plot of that statistic on the right side of the screen. Clicking on the trace buttons will show or hide the corresponding trace on the left side of the plot.

The three displayed traces are:

- Active: the input as seen by the Decimator.
- Main: this is an “idealized” representation of the carrier. The input carrier is demodulated and then reconstructed using ideal constellation points.
- Under: this is the result of removing the “main” trace from the “active” trace. This displays any mismatches or distortions present in the input signal, such as excessive noise, mismatched filtering, or interfering carriers.

If the Decimator fails to lock to the input signal, only the Active trace can be displayed.

Menu buttons are provided as follows:

- Play:  Start the carrier under carrier analysis.
- Stop:  Stop the analysis.
- *Center Frequency*: Set the center frequency in MHz.
- *Switch Port*: Select the switch port for the signal to be analyzed.
- *MODCOD*: Select the modulation and coding standard.
 - DVB-S
 - QPSK (1/2, 2/3, 3/4, 5/6, 7/8)
 - DVB-S2
 - QPSK (1/4, 1/3, 2/5, 1/2, 3/5, 2/3, 3/4, 5/6, 8/9, 9/10)
 - 8QPSK (3/5, 2/3, 3/4, 5/6, 8/9, 9/10)
 - 16APSK (2/3, 3/4, 4/5, 5/6, 8/9, 9/10)
- 32APSK (3/4, 4/5, 5/6, 8/9, 9/10) *Symbol Rate*: Set the symbol rate in MHz.
- *Roll-off*: Set the roll-off.
- *Trace*: Configure the colour, visibility, and width of each trace, or export the trace to a CSV file.

2.2.9 Query String

Normally, the GUI is started with default settings. If you find you often change the settings to the same values regularly, you can save a project and reopen it each time you use the Decimator, or you may want to take advantage of the query string function.

The GUI can be configured via the URL used to access it, so that it will start with the specified settings. You can then bookmark this URL to easily access the desired settings. For example, the URL `http://192.168.10.10/index.html?frequency=1455.5` will start the GUI with the center frequency set to 1455.5 MHz. The complete list of possible parameters is defined in the following table.

Parameter Name	Description	Expected Data Type	Example	Default Value
frequency	Sets the center frequency	Decimal, MHz	frequency=1345.23	1550
span	Sets the span	Decimal, kHz	span=24.885	40000
RBW	Sets the resolution BW	Decimal, Hz	RBW=95	RBW auto mode on
averages	Sets the number of averages	Decimal	averages=12	5
autoyaxis	Turns Y-axis auto scaling on/off	Boolean (true=on)	autoyaxis=false	true (auto scaling on)
yref	Y-axis reference value (value at the top of the plot)	Decimal (dBm)	yref=-10	-20
dbdiv	Number of dB per division on the Y-axis	Decimal (dB)	dbdiv=5	10
crosspolmode	Turns CrossPol mode on/off	Boolean (true=on)	crosspolmode=true	false (CrossPol mode off)
switchport	Selects the switched RF port (Multiport Decimator only)	Decimal (1 to 8)	switchport=5	1
crosspolswitchport	Selects the switched RF port for the CrossPol feed	Decimal (1 to 8)	crosspolswitchport=3	2
crosspolpeakmarkermode	Sets the behavior of the peak markers in CrossPol mode	Enum: Peak Lock Draggable	crosspolpeakmarkermode=Draggable	Peak Lock
autoattenuation	Toggles input attenuation between auto and manual	Boolean (true=auto)	autoattenuation=true	true (automatic attenuation)
attenuation	Sets the attenuation level in dB	Decimal	attenuation=5	0

Parameter Name	Description	Expected Data Type	Example	Default Value
referenceselect	Toggles the clock reference between internal/external	Enum: external internal auto	referenceselect=auto	internal
capturemode	Sets the capture mode	Enum: stopped single continuous	capturemode=continuous	continuous
fftwindow	Sets the FFT window	Enum: rectangular flattop blackman-harris hamming hanning	fftwindow=flattop	blackman-harris
spectralinversion	Sets the spectral inversion	Boolean (true=on)	spectralinversion=true	false
optimization	Sets the optimization or dithering option	Enum: spurious speed	optimization=speed	spurious
overviewmode	Sets the overview mode. From a command line URL, you can only set <i>Off</i> or <i>On Full Span</i> since <i>On 1</i> to <i>On 8</i> require an <i>Overview State</i> to be saved.	Enum: Off On Full Span On 1 On 2 On 3 On 4 On 5 On 6 On 7 On 8	overviewmode=On Full Span	Off
detector	Sets the detector type option	Enum: peak normal	detector=peak	normal

Parameter Name	Description	Expected Data Type	Example	Default Value
hold	Sets the hold mode	Enum: normal max hold min hold min max active	hold=max hold	normal
colorscheme	Sets the color scheme on the plot	Enum: normal print	colorscheme=print	normal
ratio	Sets the approximate number of points	Decimal	ratio=500	401
vbwmode	Set the VBW mode	Enum: averages vbw	vbwmode=vbw	averages
vbw	Set the VBW	Decimal, Hz	vbw=300	100
connectiontimeout	Sets the connection timeout	Decimal seconds	connectiontimeout=120	30
localstoragename	Loads a project XML file that you have saved in your browser at startup - if provided, all other options above are ignored and the ones in the project file are loaded in	File saved to the web browser	localstoragename=myProject	N/A

The parameters must be appended to the regular URL using the standard URL query string format (parameter list and URL separated by '?', parameters separated by '&', and parameter name/value separated by '='). The parameters can be in any order and parameter names are case insensitive. You may specify as many or as few parameters as you like.

Examples:

- `http://192.168.10.10/index.html?frequency=1350.5&span=25.5`
 - Sets the center frequency to 1350.5 MHz, and span to 25.5 kHz.
- `http://192.168.10.10/index.html?autoyaxis=false`
 - Turns off automatic Y-axis scaling.
- `http://d4-decimator-17.local/index.html?autoyaxis=false`
 - Same as previous, turns off automatic Y-axis scaling but uses the serial number style instead of the IP address in the URL.

- `http://192.168.10.10/index.html?frequency=1350.5&span=25.5&RBW=98&averages=11&referenceselect=external&capturemode=continuous`
 - Sets the center frequency to 1350.5 MHz, span to 25.5 kHz, resolution bandwidth to 98 Hz, the number of averages to 11, enables the external clock reference, then starts a continuous mode trace.

2.3 SNMP Interface

The Decimator supports read-only monitoring of Decimator status through the SNMP interface. SNMPv2 is supported. MIB definitions are available to provide translations of the OIDs to readable labels.

Decimator identification is provided in the ISO branch of the object ID structure. The ENTITY-MIB file contains the translations for these nodes. Notable entries are as follows:

.1.3.6.1.2.1.47.1.1.1.1.8	Hardware revision
.1.3.6.1.2.1.47.1.1.1.1.10	Software revision
.1.3.6.1.2.1.47.1.1.1.1.11	Serial number

Decimator status information is provided in the ISO branch as well. The IADC-MIB file contains the OID translations. Entries are as follows:

.1.3.6.1.4.1.9633.4.1.1.0	Input overload status
.1.3.6.1.4.1.9633.4.1.2.0	Overall Decimator status (indicates major fault)
.1.3.6.1.4.1.9633.4.1.3.0	System up time (how long since last reset)
.1.3.6.1.4.1.9633.4.1.4.0	1.2 VDC power supply voltage
.1.3.6.1.4.1.9633.4.1.5.0	2.5 VDC power supply voltage
.1.3.6.1.4.1.9633.4.1.6.0	5.0 VDC power supply voltage
.1.3.6.1.4.1.9633.4.1.7.0	12.0 VDC power supply voltage
.1.3.6.1.4.1.9633.4.1.8.0	17.0 VDC power supply voltage
.1.3.6.1.4.1.9633.4.1.9.0	Onboard temperature
.1.3.6.1.4.1.9633.4.1.10.0	Center frequency of current spectrum capture
.1.3.6.1.4.1.9633.4.1.11.0	Span of current spectrum capture
.1.3.6.1.4.1.9633.4.1.12.0	RBW of current spectrum capture (0 if time capture in progress)
.1.3.6.1.4.1.9633.4.1.13.0	Spectral inversion setting
.1.3.6.1.4.1.9633.4.1.14.0	Reference clock source setting
.1.3.6.1.4.1.9633.4.1.16.0	Auto attenuation setting
.1.3.6.1.4.1.9633.4.1.17.0	Number of available switch ports
.1.3.6.1.4.1.9633.4.1.18.0	Currently selected switch port

To obtain the MIB OID files, enter the filename for each into the URL field of a browser and then save the file for use by your SNMP tools. For example:

- <http://192.168.10.10/schemas/ENTITY-MIB.mib>
- <http://192.168.10.10/schemas/IADC-MIB.mib>
- <http://192.168.10.10/schemas/SEDSYSTEMS-MIB.mib>

2.4 Specifications

2.4.1 Single Port Decimator

Parameter	Specification
Power Requirements	PCIe 25 W maximum, or 3-pin Molex connector: 5V 1A and 12V 1A
Environmental	Indoor environment
Temperature	Operating: 0 to +55 °C, optionally 0 - +65 °C Non-operating: -40 °C to +70 °C
Humidity	Operating: 10% to 95% non-condensing Non-operating: 10% to 95% non-condensing
Mechanical	
Size	Half-size PCIe card, 6.875" x 4.2"
Physical Interfaces	
RF Input	SMA, 50 Ω Input frequency range: 5 MHz to 6730 MHz Input power: +5 dBm to -110 dBm (aggregate) Maximum safe input: +10 dBm
Control	RJ45, 100/1000Base-T, half-duplex or full-duplex TCP/IP API, SNMPv2, HTTPS
Reference	BNC, 50 Ω 10 MHz, -5 dBm to +13 dBm
Health Monitor LED	Green if the Decimator is ready for use Red if the Decimator has encountered an error Not illuminated if the Decimator is initializing
Trigger Inputs	Future use
PCIe x1	Used to power Decimator (cannot be controlled through the PCIe interface, this is reserved for future use. Contact Calian to discuss PCIe control options.)
Measurements	
Amplitude Accuracy	±0.5 dB (25 °C) ¹ ±1.0 dB (5 to 40 °C)
Frequency Accuracy	±2.6 ppm (internal) Or as per external reference source
Frequency Resolution	1 Hz
Resolution Bandwidth ²	1 Hz to 15 MHz
Spurious	Images: < -55 dBc (typical) Aliasing: < -55 dBc (typical) DC Offset (time domain only): < -30 dBc (typical)
Single Measurement Span	Up to 220 MHz
Multiple Measurement Span	Up to 6278 MHz



Single Port and Multiport Decimator D4 User's Manual

Parameter	Specification
Averaging	User-selectable, up to 255 averages
Measurement Speed ³	500 MHz span, 1 MHz RBW, 200 ms 200 MHz span, 30 KHz RBW, 630 ms 80 MHz span, 100 kHz RBW, 170 ms 3.5 MHz span, 8 kHz RBW, 90 ms
Modes of Operation	Raw snapshot mode: Number of IQ time samples is approximately 32 million Linear power/bin Log power/bin Raw IQ samples Selectable spectral inversion Programmatic measurement and control over Ethernet-based API

Notes:

1. Measurement conditions: 10 averages, input level between -8 dBm and -68 dBm, 3 sigma.
2. Resolution bandwidths are automatically or manually adjustable.
3. Expected rates with 10 averages, speed optimization.
4. All specification at 25 °C unless otherwise noted and are subject to change without notice.

2.4.2 Multiport Decimator

Parameter	Specification
Power Requirements	Input voltage: 120/240 VAC \pm 10% Power: 50 W maximum Input frequency: 46-63 Hz single phase AC power connector <ul style="list-style-type: none"> IEC 60320, fused power connector, spare fuse in connector. Cylindrical time delay non-indicating fuse, 5 x 20 mm, 250 V 2 A (Bussmann GDC-2A or equivalent)
Environmental	Indoor environment
Temperature	Operating: 0 to +40°C Non-operating: -20°C to +70°C, optionally -40°C to +85°C
Humidity	Operating: 0% to 50% non-condensing (maximum 80% up to 31°C, decreasing linearly to 50% at 40°C) Non-operating: 10% to 95% non-condensing
Pollution	Degree 2
Altitude	Maximum 2000 m
Installation	Category II
Standards	
EMC Standards	EN 61326-1 FCC Title 47, Part 15
Safety Standards	EN 61010-1 UL 61010-1 CSA22.2 No. 61010-1
Mechanical	
Size	1.75" H x 19" W x 10" D
Mounting	19" rack-mounted, 1U
Physical Interfaces	
RF Inputs	8 x Type F, 75 Ω (optionally SMA, 50 Ω) Input frequency range: 5 MHz to 3000 MHz (75 Ω), 5 MHz to 6730 MHz (50 Ω) Input power (per input): +5 dBm to -110 dBm (aggregate) Input isolation (port-port): 48 dB (minimum) Input return loss: -15 dB (minimum)
Control	RJ45, 100/1000Base-T, half or full duplex TCP/IP API, SNMPv2, HTTPS
Reference	BNC, 50 Ω 10 MHz, -5 dBm to +13 dBm

Parameter	Specification
Measurements	
Amplitude Accuracy	±0.5 dB (25 °C) ¹ ±1.0 dB (5 to 40 °C)
Frequency Accuracy	±2.6 ppm (internal) Or as per external reference source
Frequency Resolution	1 Hz
Resolution Bandwidth ²	1 Hz to 15 MHz
Spurious	Images: < -55 dBc (typical) Aliasing: < -55 dBc (typical) DC Offset (time domain only): < -30 dBc (typical)
Single Measurement Span	Up to 220 MHz
Multiple Measurement Span	Up to 6728.5 MHz
Averaging	User-selectable, up to 255 averages
Measurement Speed ³	500 MHz span, 1 MHz RBW, 200 ms 200 MHz span, 30 KHz RBW, 630 ms 80 MHz span, 100 kHz RBW, 170 ms 3.5 MHz span, 8 kHz RBW, 90 ms

Notes:

1. Measurement conditions: 10 averages, input level between -8 dBm and -68 dBm, 3 sigma.
2. Resolution bandwidths are automatically or manually adjustable.
3. Expected rates with 10 averages, speed optimization.
4. All specification at 25 °C unless otherwise noted and are subject to change without notice.

2.5 Maintenance

There is no on-going maintenance required for the Multiport Decimator.

2.5.1 Cleaning

On Multiport Decimators, clean the exterior of the chassis with a damp cloth ONLY. DO NOT USE ANY SOLVENTS.

2.5.2 Calibration

If the Decimator is being used for absolute level measurements, it needs to be recalibrated once every 2 years. If it is being used for general carrier detection or relative measurements, such as carrier-to-noise ratio, then no calibration is required.

2.5.3 Product Support

There are no serviceable parts inside the Decimator. If your Decimator is not operating correctly, contact the Calian service department for support at the following email or website address.

Calian, Advanced Technologies
18 Innovation Boulevard
Saskatoon, SK
Canada S7N 3R1

Telephone: 306-933-1605

Fax: 306-933-1486

Email: decimator@calian.com

Website: <https://www.calian.com/advanced-technologies-customer-support/customer-service/>

3. Appendix A: Spectator Database Installation

3.1 Overview

Since there is about 1 GB of measurement data created each day when running carrier monitoring, the Spectator solution will require an external database that you must install, configure and run to store this historical information. This step must be performed to ensure proper storage of measurement data. It will take about 60 to 90 minutes to setup after downloading all required software. This requires a moderate knowledge of software installation and system administration. You may want to consult with your network administrator to have them prepare this for you, as some of these steps will require administrator privileges.

3.2 Architecture

Before we start, let's look at the overall architecture of the Spectator solution shown in Figure 3-1. The D4 hardware unit is doing the low-level analysis of obtaining the data from the RF input feed. The client computer runs the Spectator solution in the browser. It coordinates which carriers to measure and serializes the resulting measurement data to the database, which is a Spectator Couch DB Service running in a Docker container. This container is provided by Calian with the purchase of Spectator. The supporting Docker Engine is something you will download and install on the same client computer that is running the Spectator client running in the browser. The Spectator Couch DB Service is configured to store all the data in a directory on the host computer that it is running on. More on that later...

**Install the database on the same client computer that is
running the Spectator web application in the client browser**

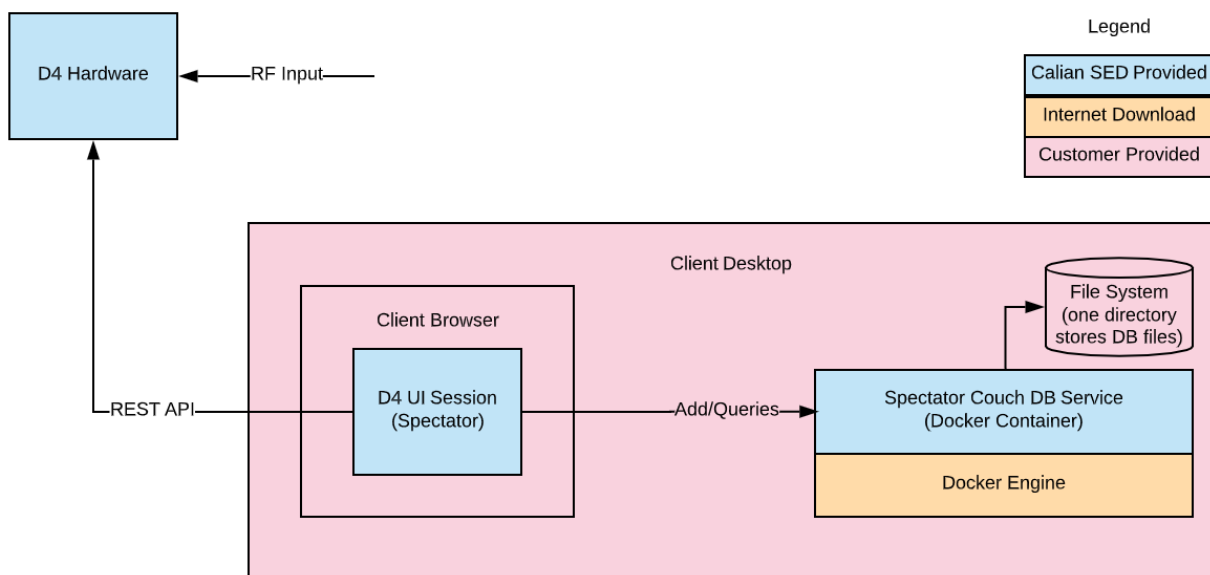

Figure 3-1 Spectator / Detector Database Deployment

3.3 Summary of Installation Steps

You will have to install the Database on the client machine where your browser is running the D4 UI. The recommended platform is a computer running a Linux 64-bit distribution or Windows 10 64-bit operating system. There are other platforms that are available, like the Mac, where deployment is similar to a Windows 10 install. The remaining sections provide details for the following basic steps required to get your Spectator Couch DB Service up and running:

- Install and run Docker Engine
- Install Spectator Couch DB Service
- Create DB directory
- Run Spectator Couch DB Service
- Run and configure Web UI DB Viewer
- Enter the Spectator Log DB Name
- Run Spectator Carrier Monitoring

3.4 Install Docker Engine

Install Docker Engine on the client machine. This is an open source piece of software that allows you to run containerized applications, like the Spectator Couch DB Service.

Follow the instructions at <https://docs.docker.com/engine/install/> and select the install according to your operating system. For Windows and Mac based platforms, you will need Docker Desktop. For Linux based platforms you will install the Docker Server.

For your convenience, we have included the Windows installation instructions:

- Get Docker Desktop for Windows and click on Get Stable button. This should start the download. Should be about 374 MB download. Consult the latest documentation on the Docker website to correctly install this.
- Once downloaded, run the installer as a normal user. You will be asked to elevate your user privileges to admin to allow the install to happen. You may need to ask your network administrator to install this as you may not have admin privileges.
- On the Configuration screen, leave everything checked as default. You will want Hypervisor installed too.
- Click OK to continue the install. This will take several minutes.
- At the end of the installation on success, you will be asked to “Close and restart” to restart your machine. Do that now.
- After the machine reboots, log in as your normal user.
- Add your username to the docker-user group in Windows (see Figure 3-2).
- Start a command terminal as administrator.

- In the Windows search, enter “cmd.exe” and in the popup window, click “Run as administrator”, select your admin account and enter the admin password
 - In the new command terminal, type “lusrmgr.msc” and <Enter>
 - The local Users and Groups Dialog appears
 - Click on Groups on the left tree
 - Double click on “docker-users”

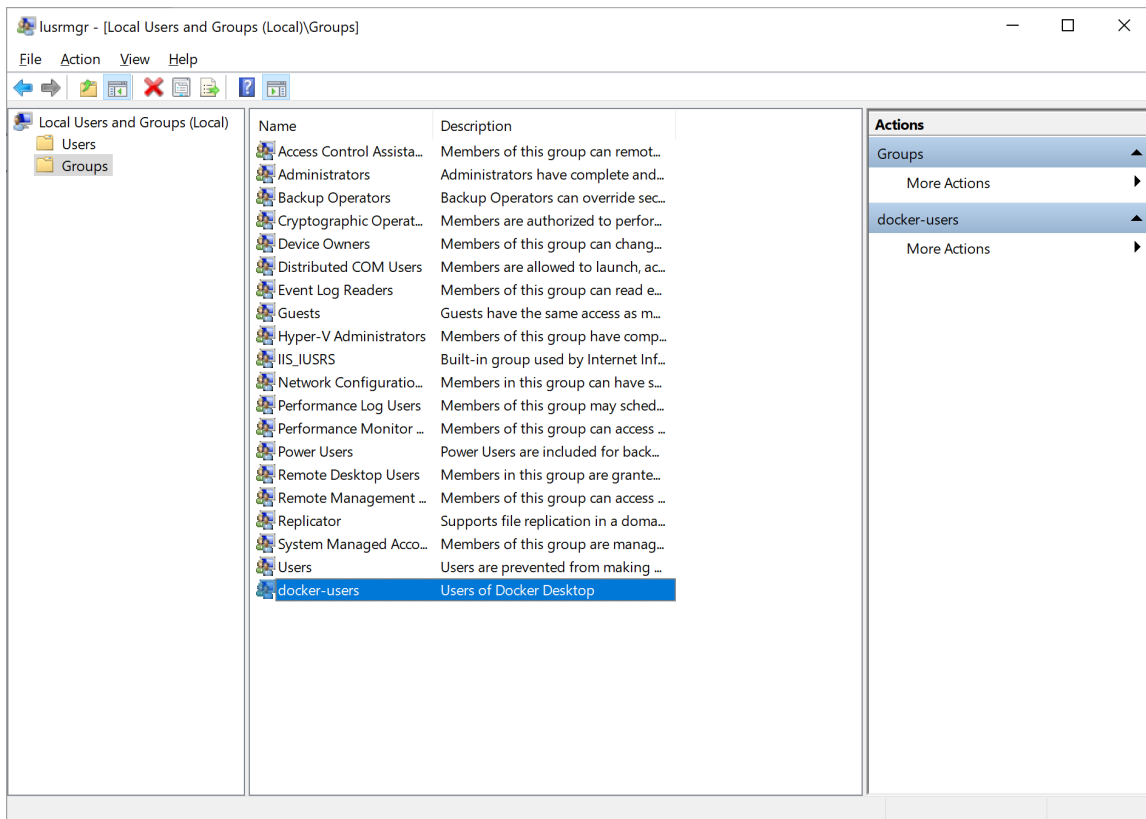

Figure 3-2 Windows Users and Groups

- Then click Add.
- In the Select Users window, enter the user name for the non-administrator account. This will be your user account, under which you will be running Docker, then click OK and save all the way to the parent dialog and close the dialog.
- To be safe, restart again.

- To navigate to Docker Desktop, in the Start menu select “Docker Desktop”. If the Docker Desktop starts, you are now running Docker. However, you may see a dialog “An error occurred. Cannot enable Hyper-V service.” If this happens you will have to enable Hyper-V in the BIOS. To do this, perform the following:
 - Restart Windows and in the BIOS settings, enable virtualization features by pressing ‘Esc’, ‘delete’, or F10 during bootup (depending on your hardware), and going to BIOS settings -> Advanced -> device settings -> select virtualization checkbox(s).
 - This is described at <https://docs.microsoft.com/en-us/virtualization/hyper-v-on-windows/quick-start/enable-hyper-v>.
 - Enable all Hyper-V checkboxes.

3.5 Run Docker Engine

Linux

Start Docker as a background service. You will want this to start automatically when your machine boots, so your database will always be running. Depending on what operating system you are running, this will vary. Check the Docker documentation and your operating system on how to best perform this. For example on Centos Linux:

- Start
 - `sudo systemctl start docker`
- Check Status
 - `sudo systemctl status docker`
- Stop
 - `sudo systemctl stop docker`
- Check if Docker is running and see its version
 - `docker --version`

You will see the following output:

```
Docker version 19.03.12, build 48a66213fe
```

Windows

In your user account, configure the Docker Desktop to start up automatically by creating a shortcut to the Docker Desktop in the startup folder. Do this by dragging the Docker Desktop icon from the Start Menu to the startup folder at:

```
C:\Users\YourUserAccount\AppData\Roaming\Microsoft\Windows\Start  
Menu\Programs\Startup
```

Restart your system. After the system starts up, Docker should be installed and running correctly. On slower hardware, it may take a minute or two for Docker Desktop to start up. To check that it is installed and running correctly, open a terminal as a normal user and type:

- “docker version”

You should see something that looks like the following:

```
C:\Program Files\Docker\Docker> docker version
Client: Docker Engine - Community
 Version:           19.03.12
 API version:       1.40
 Go version:        go1.13.10
 Git commit:        48a66213fe
 Built:             Mon Jun 22 15:43:18 2020
 OS/Arch:           windows/amd64
 Experimental:      true

Server: Docker Engine - Community
 Engine:
  Version:           19.03.12
  API version:       1.40 (minimum version 1.12)
  Go version:        go1.13.10
  Git commit:        48a66213fe
  Built:             Mon Jun 22 15:49:27 2020
  OS/Arch:           linux/amd64
  Experimental:      false
 containerd:
  Version:           v1.2.13
  GitCommit:        7ad184331fa3e55e52b890ea95e65ba581ae3429
 runc:
  Version:           1.0.0-rc10
  GitCommit:        dc9208a3303feef5b3839f4323d9beb36df0a9dd
 docker-init:
  Version:           0.18.0
  GitCommit:        fec3683
```

3.6 Download and Install Spectator Couch DB Service

Download the “SpectatorCouchDb_3_1_0AndInstructions.tar.gz” to this DB machine from the Calian SFTP site. Contact decimator@calian.com for more information.

Untar this file in a terminal using

- “tar -zxvf SpectatorCouchDb_3_1_0AndInstructions.tar.gz”

On Windows you can use 7-Zip to do the equivalent.

The contents in the tar.gz are the following:

File Name	Description
spectatorCouchDb_3_1_0.tar	This is the Spectator Couch DB Docker image that gets loaded into the Docker Engine, which provides a runtime Docker container; i.e., the Spectator Couch DB Service.
readme.txt (Figure1.png to Figure6.png)	Instructions similar to what is provided in the user manual.
scripts/installSpectatorCouchDB.sh	Installs the Spectator Couch DB Service.
scripts/startSpectatorCouchDB.sh	Starts the Spectator Couch DB Service.
scripts/stopSpectatorCouchDB.sh	Stops the Spectator Couch DB Service.

Run the scripts/installSpectatorCouchDB.sh or more simply, run the following from a terminal:

- “docker load < spectatorCouchDb_3_1_0.tar”

This installs the database service image into the Docker Engine.

Check to see if this is installed correctly by running from a terminal:

- “docker images”

You should see something that looks like the following:

- REPOSITORY TAG IMAGE ID CREATED SIZE
- spectatorcouchdb 3.1.0 d0e3dc4ecddd 24 hours ago 189MB

If you see this, your Spectator Couch DB service is installed. Now we need to start it up.

3.7 Make a Database Directory on your DB Server

Before starting up the service, we will need to make a directory where you would like to store the database files on your host computer. For the example that continues below it uses `~/Downloads/couchdb` for a Linux path, or on a Windows machine, it could be `C:\Users\someUser\couchdb`. The important point is that it should have open privileges to reading and writing by the Spectator Couch DB Docker service. This directory is something specific to your machine. Once you create it, write it down. You will use this in the next step.

3.8 Start the Spectator Couch DB Service

Start the Spectator Couch DB Service by running the following (you will need to adjust the contents of the start script to your network):

```
“docker run --name spectatordb --restart=on-failure -v  
C:/Users/someUser/couchdb:/opt/couchdb/data -p 5984:5984 -e COUCHDB_USER=admin -e  
COUCHDB_PASSWORD=password -d spectatorcouchdb:3.1.0
```

Let's look at each of these and explain them:

- `docker run --name spectatordb`
 - This tells the Docker engine to run an image and name the instanced container `spectatordb`.
- `--restart=on-failure`
 - This tells the Docker engine to restart the service if it fails for some error.
- `-v C:/Users/someUser/couchdb:/opt/couchdb/data`
 - This tells Docker where to mount the volume outside the container on your host computer to serialize the DB records
 - The first half is database directory you created on your host DB computer in the previous step, for example, `C:/Users/someUser/couchdb`. Adjust this to what you wrote down and ensure the directory is created with read write permissions. This is the directory where the database will write and read records from. The second half of `/opt/couchdb/data` is to be left as is. It is a directory inside the running Docker container.
- `-p 5984:5984`
 - Format is `externalPort:internalPort`. This tells Docker to expose the external http port 5984. The external port can be any free port number, but the internal port must be 5984. Whatever you use for the first number, you will use for the DB Logging URL later from inside of Spectator.

- -e COUCHDB_USER=admin -e COUCHDB_PASSWORD=password
 - This provides security to the database. You can configure these to whatever you want. Make sure you keep these user and password text in a safe place as you will need to set these when configuring the parameters for the Spectator URL connection and for logging into the Web DB Viewer.
- -d
 - Run in the background mode.
- spectatorcouchdb:3.1.0”
 - Tell Docker which image to start up. This will be the same as when you run Docker images.

In summary, modify the C:/Users/someUser/couchdb and the username and password. Save this in a script of your choice. Then run the script.

3.9 Verify the Spectator Couch DB Service is Running

From the command line terminal as a normal user, run

- docker ps
- You will see something like the following output

CONTAINER ID	IMAGE	COMMAND	CREATED	STATUS
5343be232d1b	d0e3dc4ecddd	"tini -- /docker-ent..."	3 days ago	Up 3 days
0.0.0.0:5984->5984/tcp, 4369/tcp, 9100/tcp		spectatordb		

3.10 Run the Web UI DB Viewer and Configure as a Single Node

- a. In a browser, navigate to http://localhost:5984/_utils (see Figure 3-3Figure 3).
- b. Make sure you don't forget the underscore in front of the utils so it is `_utils` at the end of the URL.
- c. Once on the web page, you will login with the same username and password as you have specified from a previous step when you started the container.

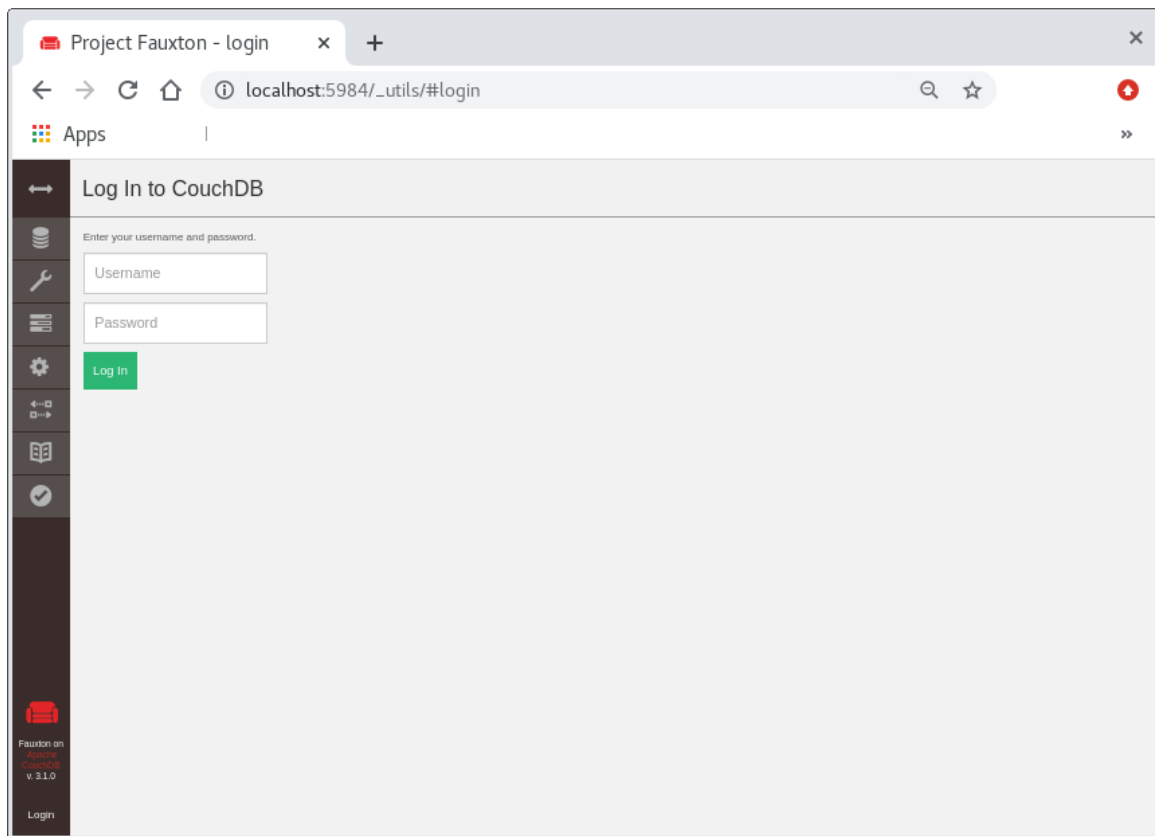

Figure 3-3 Couch DB Web UI Login

- d. Now configure as a single node (see Figure 3-4).
- e. Click on the wrench icon. You will see the following:

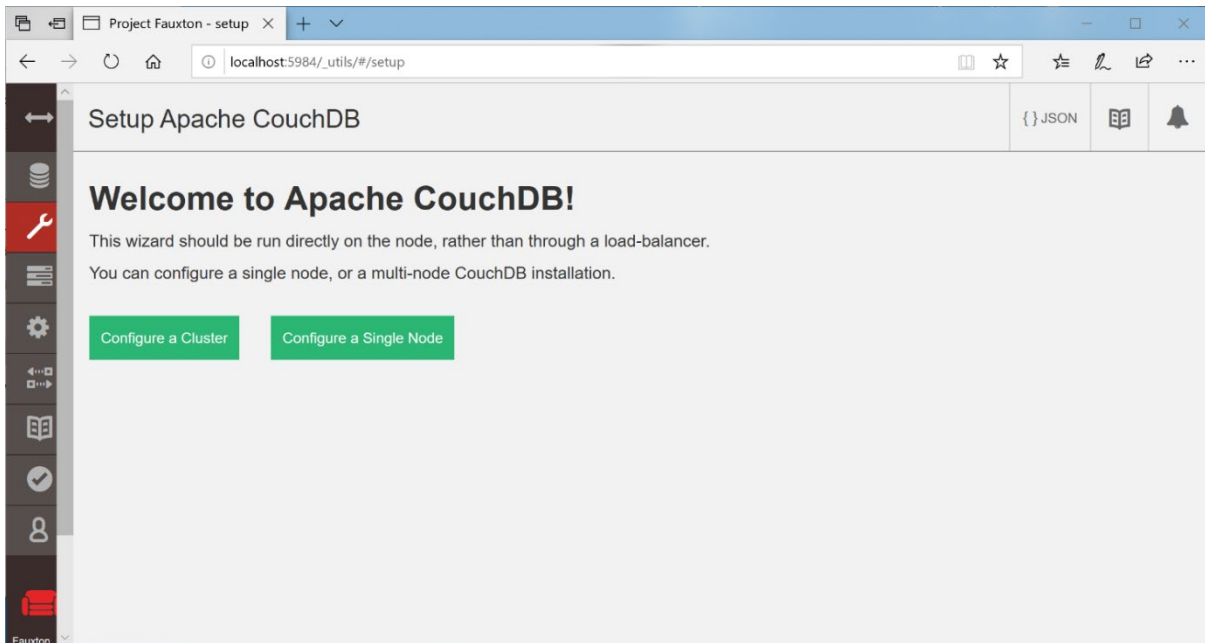

Figure 3-4 Configuring Single Node

- f. Click the Configure a Single Node and enter your user and password, the same as you did when you started the Spectator Couch DB service and keep everything else as default. Then click Configure Node button (see Figure 3-5).

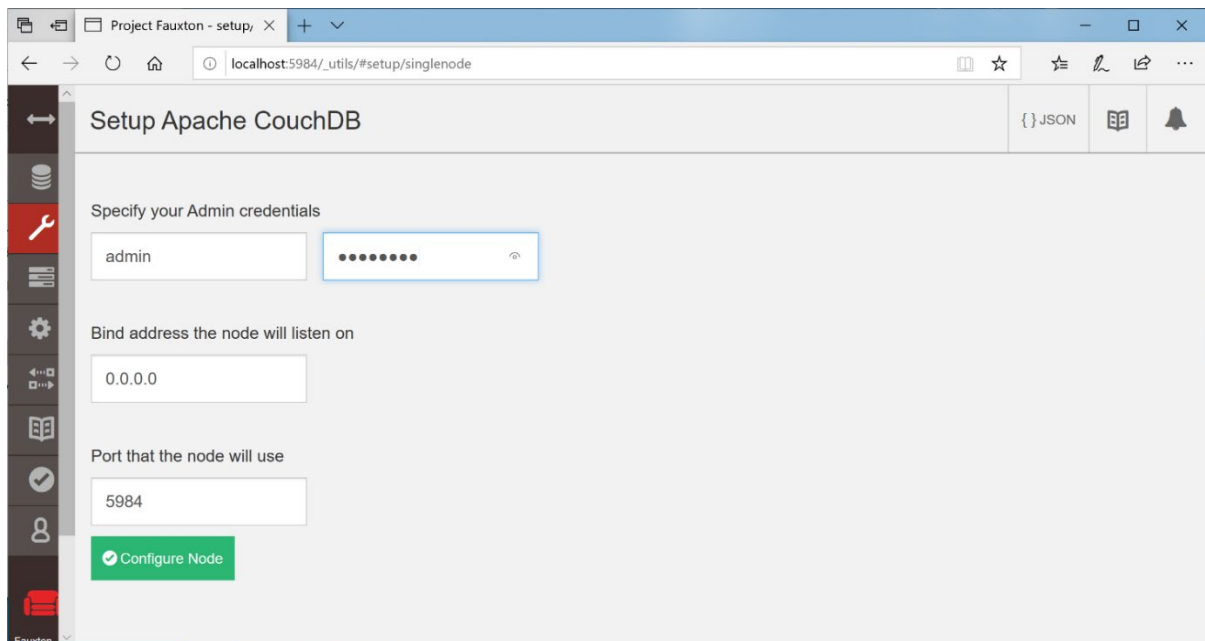

Figure 3-5 Configuring Single Node Continued

- g. You are now ready in the database to receive data. Congratulations! There is no need to replicate data (see Figure 3-6).

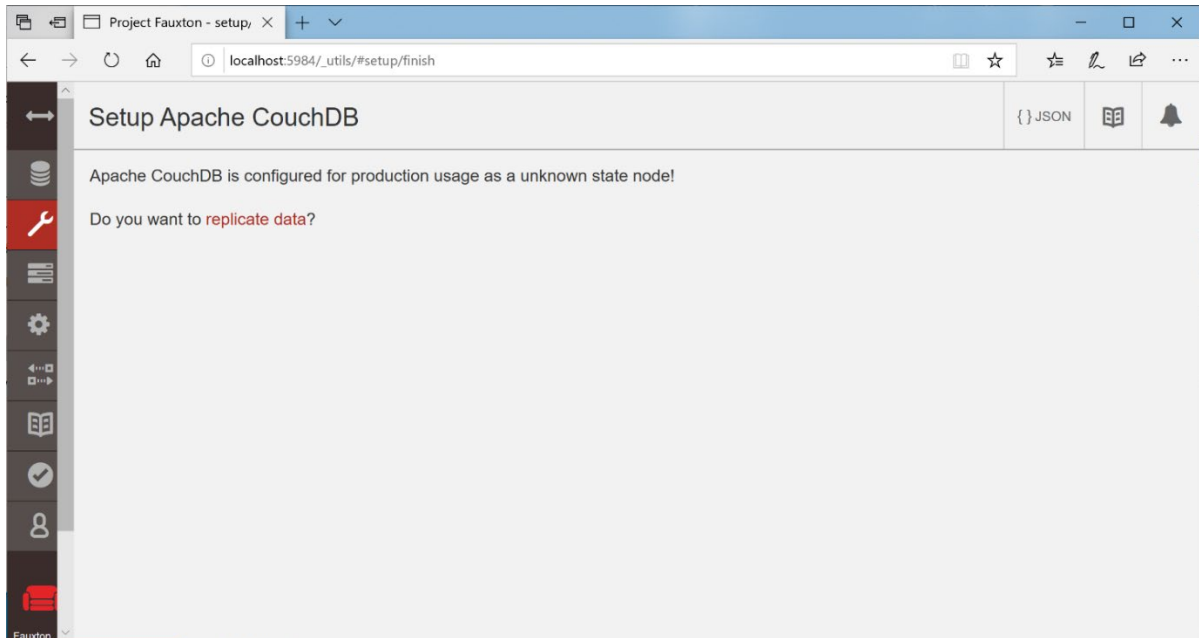

Figure 3-6 Replicate Data (No need to replicate)

- h. Clicking the DB icon (just above the wrench icon) will show you data, once you start carrier monitoring in Spectator.

3.11 Specify the Log Database Name in Spectator UI Configuration

Run the D4 UI and configure the Log Database Name in the D4 Carrier Monitoring menu to be a unique database name used to store spectrum, constellation, and analyses data (~ 1 GB per day):

- Enter some string in the following format:
`http://user:password@ipaddress:httpPort/dbName`
- For example: `http://admin:password@localhost:5984/myDb`
- where
 - `http` = we are using Hypertext Transfer Protocol
 - `user` and `password` = the same as the command line options passed into the SpectatorCouchDb Docker container
 - `ipaddress` = IPV4 internet address of the host computer of the spectator Couch DB Docker container that is running locally, i.e. localhost
 - `httpPort` = 5984 or whatever is exposed on the Docker container external port for http that you used when you started the container
 - `dbName` = any string you want to store the information in the database under. This will act as a prefix to the database name in the DB Viewer.

To automatically purge this data after many days, set the log file lifespan to something other than 0 days. We recommend setting it to 7 days to keep your disk utilization low. You can set it to 30 days to store about 1 month before Spectator cleans old data. Remember, about 1 GB of data per day is stored.

3.12 Run Spectator Carrier Monitoring

Start the carrier monitoring. You can use the Web DB Viewer to confirm that data is being correctly stored in the database.

3.13 Stop the Spectator Couch DB

If you need to stop the Couch DB Service, from the command line terminal run

- `docker stop spectatordb`
- `docker container rm spectatordb`